



**|T8000D|Series High Performance Spindle
Servo Driver
Manual**

Thank you very much for choosing T8000D series multi-function high-performance spindle servo drive.

Please read the operation manual carefully before installation, operation, maintenance or inspection in this manual, the safety precautions were sorted to “WARNING” or “CAUTION”.

“ WARNING” Indicates a potentially dangerous situation which, if can not avoid will result in death or serious injury.

“ CAUTION” Indicates a potentially dangerous situation which, if can not avoid will cause minor or moderate injury and damage the device.

This symbol is also used for warning any un-safety operation. In some cases, even the contents of “CAUTION” still can cause series accident. Please follow these important precautions in any situation.

The figures in this instruction manual are for convenience with description, they may have slight differences compared to the product, and the product update can also cause slight differences between the figure and product, the actual sizes are subject to actual products.

Please keep the operation manual handy for future reference, maintenance, inspection and repair.

If you have any questions, please contact us or our agents in time, you will always receive our best attention,

Contents

Chapter 1 Introduction	
1.1 Technology Features.....	
1.2 Description of Name Plate.....	
1.3 Selection Guide.....	
1.4 Installation.....	
Chapter 2 Installation and wiring	
2.1 Wiring of external devices.....	
2.2 Terminal wiring.....	
2.3 Main loop wiring example.....	
2.4 Control loop terminals.....	
2.5 Basic wiring.....	
2.6 Accessories optional and connector definition.....	
2.7 Connection of main loop.....	
2.8 Connection of control loop.....	
2.9 The install of EMC requirement.....	
Chapter 3 Operation	
3.1 Operator Panel instructions.....	
3.2 Operation Process.....	
3.3 Running State.....	
3.4 Quick Testing.....	
Chapter 4 Detailed Function Parameter list	
Chapter 5 Fault checking and ruled out	
5.1 Fault alarm and countermeasures.....	
Chapter 6 Maintenance	
6.1 Inspection.....	
6.2 Periodic Maintenance.....	
6.3 Replacement of wearing parts.....	
6.4 Warranty.....	
Chapter 7 Peripheral Devices Selection	
7.1 DC reactor.....	
7.2 AC input reactor.....	
7.3 AC output reactor.....	
7.4 Applied Braking resistor Specification.....	

Chapter 1 Introduction

1.1 Technology Features

Item	T8000D	
Maximum frequency	Vector control: 0~1000Hz V/F control: 0~1500Hz	
Carrier frequency	0.8kHz~16kHz The carrier frequency is automatically adjusted based on the load features.	
Input frequency resolution	Digital setting:0.01Hz Analog setting: Maximum frequency x 0.025%	
Control Mode	Sensorless flux vector control (SVC) Close-loop vector control (FVC) Voltage/Frequency (V/F) control	
Start torque	G type: 0.5Hz/150%(SVC); 0Hz/180%(FVC)	
Speed range	1: 100(SVC)	1: 1000(FVC)
Speed stability accuracy	±0.5%(SVC)	±0.02%(FVC)
Torque control accuracy	±5%(FVC)	
Overload capacity	G type: 60s for 150% of the rated current, 3s for 180% of the rated current.	
Torque boost	Auto-boost; Customized boost: 0.1%~30.0%	
V/F Curve	Straight-line V/F curve Multi-point V/F curve N-power V/F curve (1.2-power, 1.4-power, 1.6-power, 1.8-power, square)	
Ramp Mode	Straight-line ramp. Four groups of acceleration/deceleration time with the range of 0.00~6500.0s	
DC braking	DC braking frequency : 0.00Hz~Maximum frequency Braking time: 0.0s~36.0s Braking action current value : 0.0%~100.0%	

Auto voltage regulation (AVR)	It can keep constant output voltage automatically when the mains voltage changes
Rapid current limit	It helps to avoid frequent over current faults of the AC drive.
Support for kinds of PG cards	Differential input PG card; Rotating transformer PG card, 开路集电极
Power dip ride through	The load feedback energy compensates the voltage reduction so that the AC drive can continue to run for a short time
Overvoltage/overcurrent stall control	The current and voltage are limited automatically during the running process so as to avoid frequent tripping due to over voltage/over current
Torque limit and control	It can limit the torque automatically and prevent frequent over current tripping during the running process. Torque control can be implemented in the FVC mode.
Onboard multiple preset speeds	It implements up to 16 speeds via the simple PLC function or combination of X terminal states
Support motor type	Asynchronous motor, spindle asynchronous motor, Permanent Magnet Synchronous Motor, Spindle Synchronous Motor

1.2 Description of Name Plate

MODEL:T8400D-3R7G/5R5P

INPUT: 3PH 380V 50Hz/60Hz

OUTPUT: 3PH 380V 9A

FREQ RANGE: 0.1-1000Hz 3.7kW/5.5kW



140113111111

MODEL: T - 8- 400D- 3R7G/5R5P

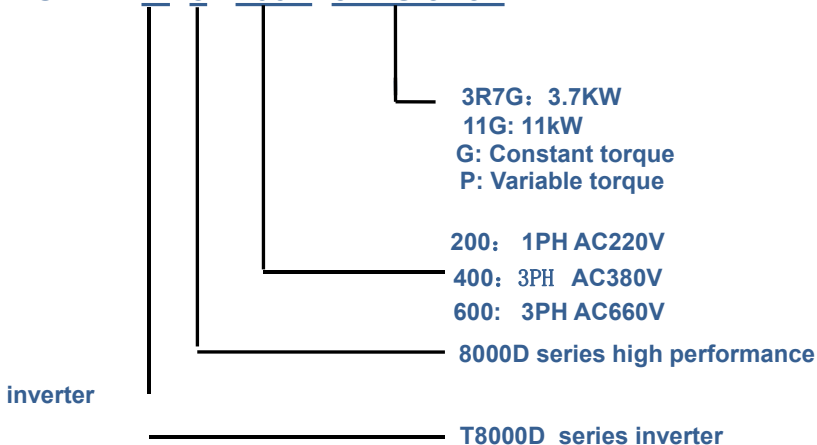

1.3 Selecton Guide

Power voltage: 3PH AC380V \pm 15%

Model No.	Input voltage	Rated output power (kW)	Rated input current(A)	Rated output current (A)	Motor Power(kW)
T8400D-3R7G/5R5P	3PH AC380V \pm 15%	3.7/5.5	10.0/15.0	9.0/13.0	3.7/5.5
T8400D-5R5G/7R5P		5.5/7.5	15.0/20.0	13.0/17.0	5.5/7.5
T8400D-7R5G/11P		7.5/11	20.0/26.0	17.0/25.0	7.5/11
T8400D-11G/15P		11/15	26.0/35.0	25.0/32.0	11/15
T8400D-15G/18R5P		15/18.5	35.0/38.0	32.0/37.0	15/18.5
T8400D-18R5G/22P		18.5/22	38.0/46.0	37.0/45.0	18.5/22
T8400D-22G/30P		22/30	46.0/62.0	45.0/60.0	22/30

1.4 Installation

1.4.1 Environment Requirement

Inverter's installation environment on the service life of inverter, and has direct influence on the normal function, Inverter can't satisfy the specification of environment, protection or fault could lead to the Inverter z2000 series inverter of wall hung inverter, please use the vertical installation so that the air convection and the heat dissipation effect can be better.

Inverter's installation environment, please make sure it must comply with

(01) - 10 °C to + 40 °C ambient temperature

(02) Environment humidity 0 ~ 95% and no condensation

(03) Avoid direct sunlight

(04) Environment does not contain corrosive gas and liquid

(05) Environment without dust, floating fiber, cotton and metal particles

(06) Away from the radioactive material and fuel

(07) Away from electromagnetic interference source (such as electric welding machine, big power machine)

(08) Installed planar solid, no vibration, if it cannot avoid vibration, please add antivibration pads to reduce the vibration

(09) Please install the inverter in the well ventilated place, easy to check and maintain , and install on the solid non-combustible material, away from the heating element (such as braking resistance, etc.)

(10) Inverter can output the rated power when installed in the altitude of lower than 1000m. It will be derated when the altitude is higher than

1000m.

(11) Inverter's installation ,please reserve enough space, especially many inverters' installation, please pay attention to the placement of the Inverter, and configure cooling fans, make the environment temperature lower than 45 °C .

(1)Single Inverter Installation:

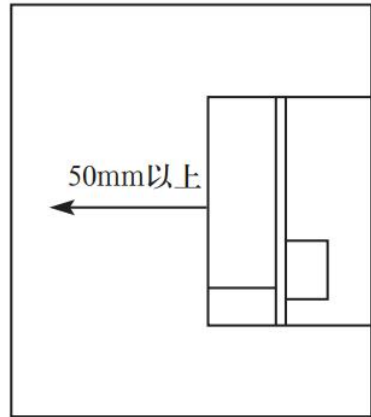
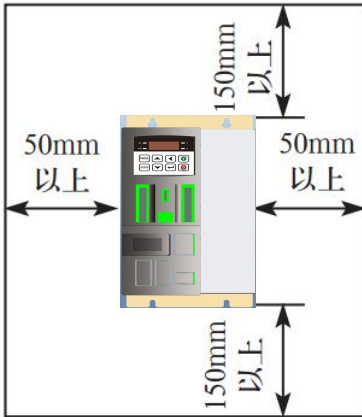

(2) Multiple inverters installed in one control cabinet

① When encasing the multiple inverters, install them in parallel as a cooling measure.

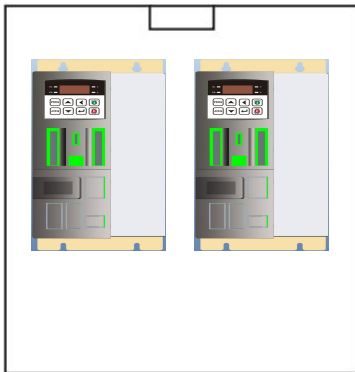

Favorable placing

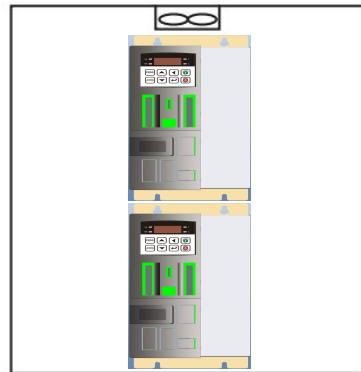

Unfavorable placing

② If multiple inverter are installed in one control cabinet, please leave enough clearances and take cooling measure.

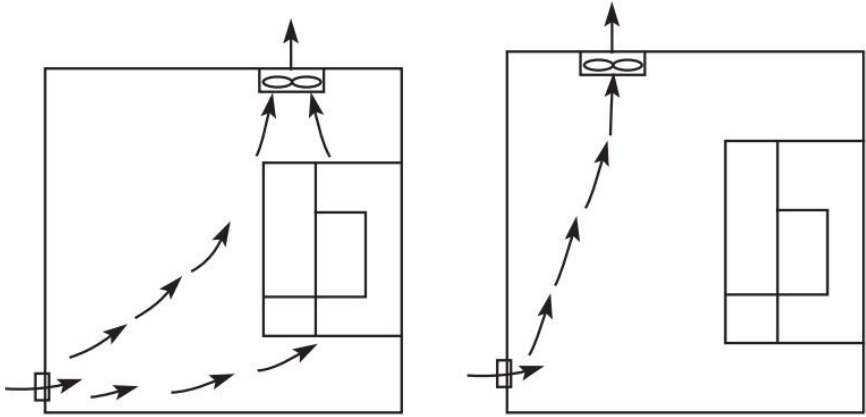

Correct installation position of the fan Incorrect installation position of the fan
1.4.2 The inverter's outside shape and installation dimensions

① 3.7-7.5kW

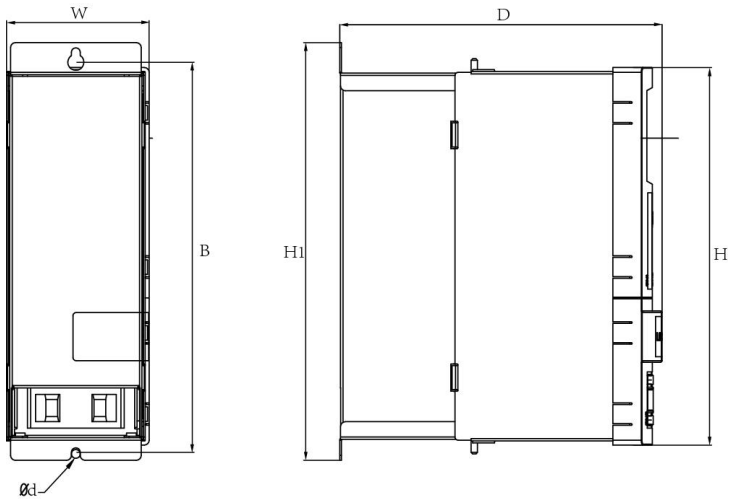

②11-22kW

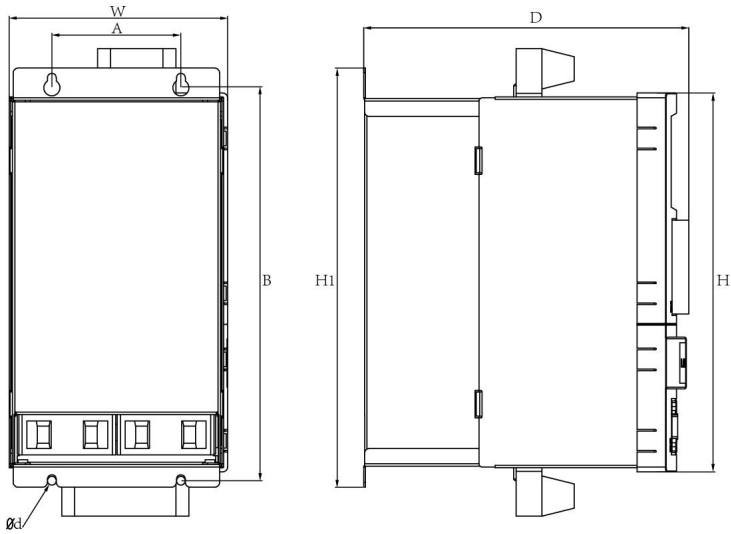

Model	Outline dimention (mm)				Installation Size (mm)			Unit: mm
	W	H	H1	D	A	B	Φd	Installation
T8400D-3R7G/5R5P	88.5	235	260	200	-	250	5.5	Wall-mounted
T8400D-5R5G/7R5P								
T8400D-7R5G/11P								
T8400D-11G/15P	135.5	235	260	202	80	250	5.5	
T8400D-15G/18R5P								
T8400D-18R5G/22P	192.5	235	260	222	132	250	5.5	
T8400D-22G/30P								



WARNING

•Only the person, who has passed the training on the design, installation, commissioning and operation of the device and gotten the certification, is permitted to operate this equipment.

•Even if the inverter is not running, the following terminals still have dangerous voltage:

-Power Terminals: R,S,T

-Motor Connection Terminals: U,V,W

•When power off, should not install the inverter until 10 minutes later, which can ensure the device discharge completely.

•Do not connect the power supply to output terminals (U, V, W), other wise it will cause the drive damage.

•Before power on, please make sure the R,S,T and U,V,W are connected correctly.

•Do not touch the inverter with wet hands, other wise, the electric shock may happen.



CAUTION

•Make sure the rated voltage of the inverter is corresponding to the AC power voltage.

•Make sure the power supply cable and motor cable are well connected.

Chapter2 Wiring

2.1 Connection of Peripheral Devices

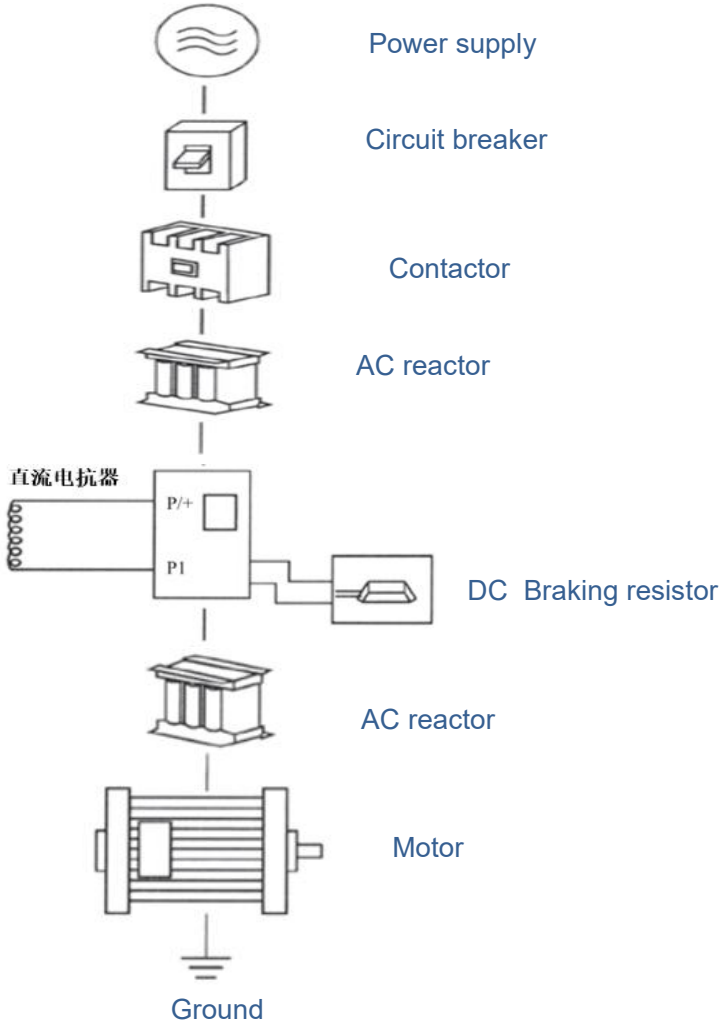

2.2 Terminal Configuration

2.2.1 Main Circuit Terminals

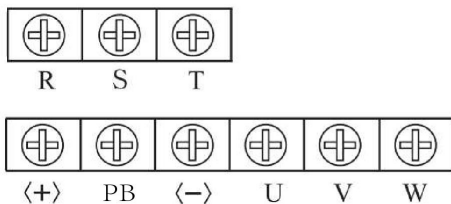

2.2.2 Main circuit terminal description

Terminal Symbol	Description
E、 	Terminal of ground
R、S、T	Power input
(+)	DC voltage “+”
PB	Braking unit can be connected
(-)	DC voltage “-”
U、V、W	Connect to AC motor

2.3 Main circuit wiring diagram

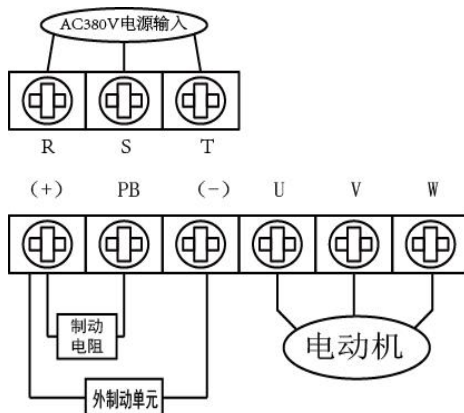

Note: Connect correctly to terminals when wiring, otherwise, the inverter may damage.

2.4 Control Circuit Terminals

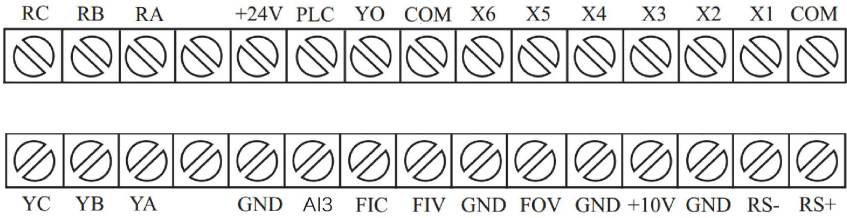

2.5 Typical Wiring Diagram

Note: Below 37kW(Include) built in brake unit.

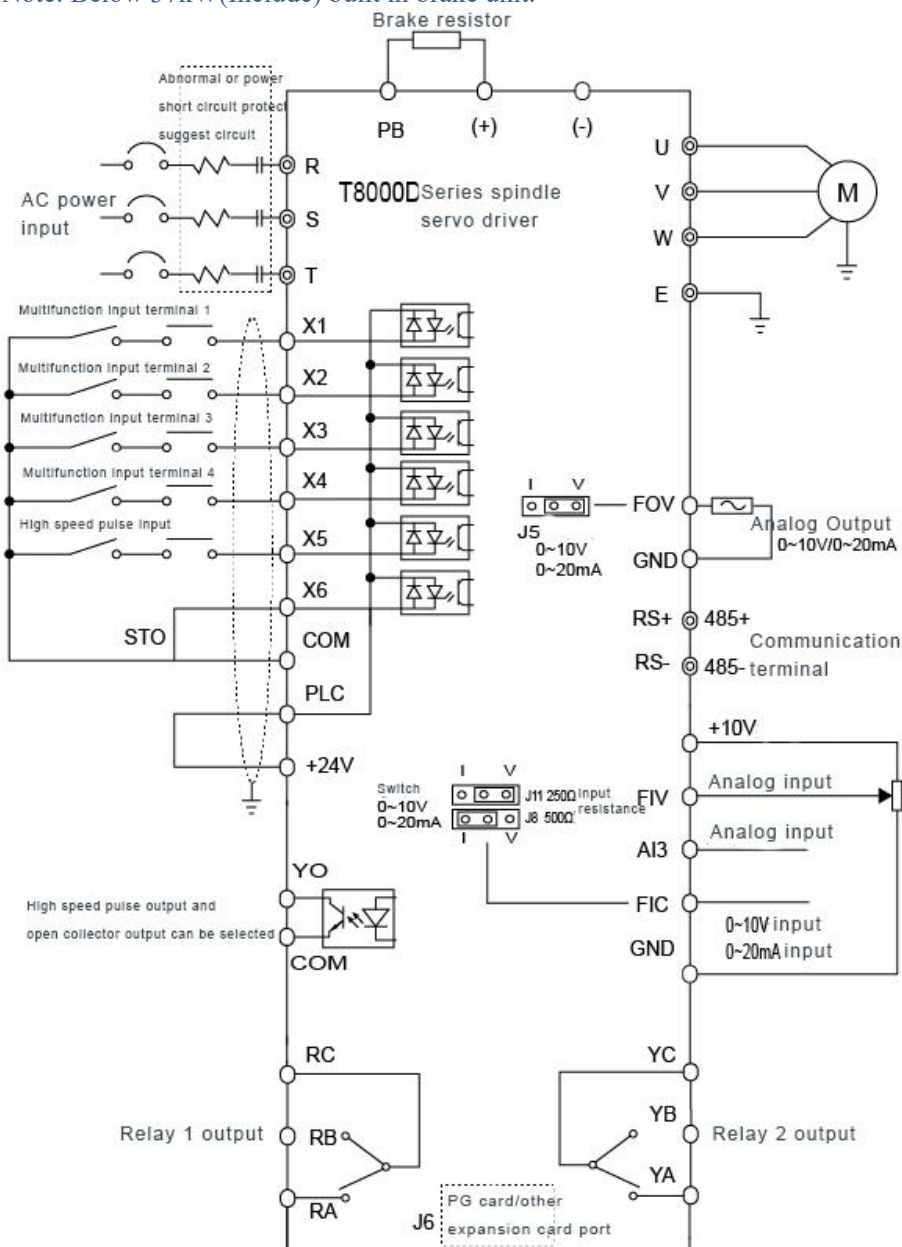

2.6 Optional selection and interface definition

Introduction: T8000D series support for kinds of PG card(optional), it is the necessary option for close loop vector control, choose them with different output type. Model as below.

Optional	Description	Wiring
PG-T1	Differential +OC PG card	DB9 receptacle (CN3+CN4)
PG-T2	Rotating PG _(PTC and CAN optional)	DB9 receptacle (PTC and CAN terminal wiring)
PG-T3	OC+OC PG	DB9 receptacle (CN3+CN44)
PG-T4	Differential + Differential_PG	DB9 receptacle (CN3+CN4)

(1) Control Terminal

Type	Terminal symbol	Name	Function
Power supply	+10V-GND	External + 10V power supply	Offer +10V power supply, maximum output current: 10mA , normally use for connect potentiometer power supply, range of resistance: 1k Ω ~5k Ω
	+24V-COM	External + 24V power supply	Offer +24V power supply, normally use for digital input output terminal power supply and for connect sensor, maximum output current: 200mA
	PLC	External power supply input terminal	Default to Connect the U type short patch and +24V; if want to connect with COM, it should disconnect the U type short patch; When drive X1~X6 with external signal, PLC should connect with external power supply, also need to disconnect the U type short patch.
Analog input	FIV-GND	Analog input terminal 1	Input voltage range: DC-10V~+10V Input impedance: 22k Ω
	FIC-GND	Analog input terminal 2	Input range: DC0V~10V/0mA~20mA, it depend on the wire jumper J8/J11 on the control board; Input impedance: while vottage input, 22k Ω can be selected, while current input, 500 Ω /250 Ω can be selected.
	AI3-GND	Analog input terminal 3	Input voltage range: DC-10V~+10V Input impedance: 22k Ω
Digital input	X1-COM	Digital input 1	Optocoupler isolation, compatible bipolar input(default to be effective when low electrical level) Input impedance: 1.8k Ω ; voltage range when electrical level input:
	X2-COM	Digital input 2	
	X3-COM	Digital input 3	
	X4-COM	Digital input 4	

			9V~30V
	X5-COM	High speed pulse input	Besides the X1~X4 features, it can be used as high speed pulse input channel. Maximum input frequency: 100kHz
	X6-COM	STO	Torque safely removed; default to connect the U type short patch with COM
Analog output	FOV-GND	Analog output	The J5 wire jumper select the voltage or current output; voltage output range: 0~10V, current output range: 0mA~20mA
Digital output	YO-COM	High speed pulse output	YO-COM high speed pulse output, Optocoupler isolation, it affected by “Y0P output function selection” on”P5.06”, as high speed pulse output, maximum frequency 100kHz, can be used as low speed open-collector output; Output voltage range: 0V~24V, output current range: 0mA ~50mA
Relay output	RA-RB	Normal close terminal	Contactor drive capacity: 250Vac/3A ; 30Vdc/1A
	RA-RC	Normal open terminal	
	YA-YB	Normal close terminal	
	YA-YC	Normal open terminal	
Auxiliary connector	J6	PG card/ other expansion charge connector	OC, ABZ, Rotating can be selected
	CN2	External keypad connector	External keypad

(2) Optional Parts

①OC card

No.	Name	Description	OC terminal definition
1	A	Encoder output A signal	
2	B	Encoder output B signal	
3	Z	Encoder output Z signal	
4	+15V	Offer 15V/100mA power supply	
5	COM	Power ground	
6	COM	Power ground	
7-9	-	-	

② ABZ card

No.	Name	Description	ABZ terminal definition
1	A+	Encoder output A signal+	
2	A-	Encoder output A signal-	
3	B+	Encoder output B signal+	
4	B-	Encoder output B signal-	
5	Z+	Encoder output Z signal+	
6	-	-	
7	+5V	Offer 5V/100mA power supply	
8	COM	Power ground	
9	Z-	Encoder output Z signal -	

③Rotating card (CAN communication and PTC optional)

No.	Name	Description	Rotating terminal definition
1	REF-	Excitation signal	
2	REF+		
3	SIN+	SIN feedback signal	
4	SIN-		
5	COS+	COS feedback signal	
9	COS-		
6-8	-	-	

④CAN communication and PTC optional connector definition: Terminator

No.	Name	Description
1	PTC-	Temperature switch
2	PTC+	
3	COM	Earth
4	CANL	CAN - Input
5	CANH	CAN + Input

(3) Peripheral Devices Specification

Drive Model	Input voltage	KW Motor	Main Circuit Cable Type (mm ²)	Breaker Selection A	Magnetic Contrator A

T8400D-3R7G/5R5P	380VAC	3.7/5.5	1.5	16	12
T8400D-5R5G/7R5P		5.5/7.5	2.5	20	18
T8400D-7R5G/11P		7.5/11	4	32	25
T8400D-11G/15P		11/15	4	40	32
T8400D-15G/18R5P		15/18.5	6	50	38
T8400D-18R5G/22P		18.5/22	10	50	40
T8400D-22G/30P		22/30	10	63	50

2.7 Connection of the Main Circuit

2.7.1 Connection of the main circuit power

2.7.1.1 Circuit Breaker

It is necessary to connect a circuit breaker which is compatible with the capacity of inverter between 3ph AC power supply and power input terminals (R,S,T). The capacity of breaker is 1.5~2 times to the rated current of inverter. For details, see <specifications of Breaker, Cable, and Contactor>.

2.7.1.2 Electromagnetic contactor

In order to cut off the input power effectively when something is wrong in the system, contactor should be installed at the input side to control the ON-OFF of the main circuit power supply.

2.7.1.3 Input AC reactor

In order to prevent the rectifier damage result from the large current, AC reactor should be installed at the input side. It can also prevent rectifier from sudden variation of power voltage or harmonic generated by phase-control load.

2.7.2 Wiring at inverter side of main circuit

2.7.2.1 DC reactor

DC reactor can improve power factor, it can prevent the rectifier bridge distorsion when overload due to connect a big capacity transformer, it can prevent the distorsion of the rectifier circuit while power grid suddenly change or phase control overload.

2.7.2.2 Braking unit and braking resistor

Inverter of 380V 37kW have built-in braking unit. In order to dissipate the regenerative energy generated by dynamic braking, the braking resistor should be installed at (+) and PB terminals. The wiring length of the braking resistor should be less than 5m. The temperature of braking resistor will increase because the regenerative energy will be transformed to heat. Safety protection

and good ventilation is recommended.

Be sure that the electric polarity of (+)(-) terminal is right; it is not allowed to connect (+) with (-) terminals directly, otherwise damage or fire may occur.

Output reactor must be installed in the following condition. When the distance between inverter and motor is more than 50m, inverter may be tripped by over-current protection frequently because of the large leakage current resulted from the parasitic capacitance with ground. And the same time to avoid the damage of motor insulation, the output reactor should be installed.

2.7.4 Grounding wiring (E)

In order to ensure safety and prevent electrical shock and fire, terminal E must be grounded with ground resistance. The ground wire should be big and short, and it is better to use copper wire ($>3.5 \text{ mm}^2$). When multiple inverters need to be grounded, do not loop the ground wire.

2.8 Control loop wiring

2.8.1 Attention

Please use multi core shielded cable or twisted pair to connect terminals, connect to the ground terminal E while use shield cable. When wiring, control cable should be more than 20cm away from power cable, motor cable, relay cable, contactor cable. Do not make it parallel wiring, but vertical wiring, in case of malfunction due to external interfere.

2.8.2 Terminal of control board

Terminal Name	Description
X1-X6	ON-OFF signal input, optical coupling with PLC and COM Input voltage range: 9-30V Input impedance: 3.3k Ω
X5	High speed pulse of ON-OFF signal input, optical coupling with PLC and COM. Pulse input frequency range: 0-50kHz Input voltage range: 9-30V Input impedance: 1.1k Ω
PLC	External power supply. +24V terminal is connected to PLC terminal as default setting. If user need external power supply, disconnect +24V terminal with PW terminal and connect PLC
+24V	Terminal with external power supply. Provide output power supply of +24v. Maximum output current: 150mA
COM	Common ground terminal for digital signal +24V (or external power supply)
FIV	Analog input, power range: 0~10V input impedance: 20k Ω
FIC	Analog input, 0~10V/0~20mA, switched by J8. Input impedance :10k Ω (voltage input)/250 Ω (current input)
+10V	Supply +10V for inverter
GND	Common ground terminal of analog signal and +10V. GND must isolated from COM.

YO	Ground terminal is COM. Output frequency range: 0~50kHz
FOV	Analog output terminal. Provide voltage or current output which can be switched by J5. Output range: 0~10V, 0~20mA
RA/RB/RC	AC250V/3A, DC30V/1A Relay output: RC-common; RB-Normal close; RA- Normal open; Capacity: AC250V/3A, DC30V/1A
YA/YB/YC	AC250V/3A, DC30V/1A Relay output: YC-Comon; YB- Normal close, YA- Normal open; Capacity: AC250V/3A, DC30V/1A
RS+/RS-	485 communication port. Please use shielded cable or twisted pair to connect RS485.

2.8.3 Switch description on control board

Switch	Switch Introduction
J5	Voltage (0~10V)/ Current (0~20mA) Input Switch, connect V,GND, it is voltage input, Connect I,GND , it is current input.
J8、 J11	Voltage(0~10V)/Current (0~20mA) output switch J8: 500 Ω input impedance J11: 250 Ω input impedance
JP4、 JP13	Anti-jamming switch. When external interference is too large to run the inverter, try to close the switch.

External potentiometer should $>3K$, power consumption should $> 1/4W$, suggest to choose $5\sim 10K\Omega$.

2.9 Installation Guidline to EMC compliance

2.9.1 EMC

EMC is the abbreviation of electromagnetic compatible, which means the device or system has the ability to work normally in the electromagnetic environment and will not generate any electromagnetic interference to other equipment.

According to the transmission mode, Electromagnetic interference can be divided into two categories: conducted interference and radiated interference. Conducted interference is the interference transmitted by conductor. Therefore, any conductors (such as wire, transmission line, inductor, capacitor and so on) are the transmission channels of the interference.

Raidated interference is the interference transmitted in electromagnetic wave, and the energy is inverse proportional to the square of distance.

Three necessary conditions or essentials of electromagnetic interference are: interference source, transmission channel and sensitive receiver. For

customers, the solution of EMC problem is mainly in transmission channel because of the device attribute of disturbance source and receiver can not be changed.

2.9.2 Like other electric or electronic devices, inverter is not only an electromagnetic interference source but also an electromagnetic receiver. The operating principle of inverter determines that it can produce certain electromagnetic noise. At the same time inverter should be designed with certain anti-jamming ability to ensure the smooth working in certain electromagnetic environment. Following is its EMC features:

2.9.2.1 Input current is non-sine wave. The input current includes large amount of high-harmonic waves that can cause electromagnetic interference, decrease the grid power factor and increase the line loss.

2.9.2.2 Output voltage is high frequency PWM wave, which can increase the temperature rise and shorten the life of motor. And the leakage current will also increase, which can lead to the leakage protection device malfunction and generate strong electromagnetic interference to influence the reliability of other electric devices.

2.9.2.3

As the electromagnetic receiver, too strong interference will damage the inverter and influence the reliability of other electric devices.

2.9.2.4 In the system, EMS and EMI of inverter coexist. Decrease the EMI of inverter can increase its EMS ability.

2.9.3 EMC installation guideline

In order to ensure all electric devices in the same system to work smoothly, this section, based on EMC features of inverter, introduces EMC installation process in several aspects of application (noise control, site wiring, grounding, leakage current and power supply filter). The good effective of EMC will depend on the good effective of all of these five aspects.

2.9.3.1 Noise control

All the connections to the control terminals must use shielded wire. And the shield layer of the wire must ground near the wire entrance of inverter. The ground mode is 360 degree annular connection formed by cable clips. It is strictly prohibitive to connect the twisted shielding layer to the ground of inverter, which greatly decrease or loses the shielding effect.

2.9.3.2 Site wiring

Power supply wiring: the power should be separated supplied from electrical transformer. Normally it is 5 core wires, three of which are fire wires, one of which is the neutral wire, three of which is the ground wire. It is strictly prohibitive to use the same line to be both neutral wire and the ground wire.

Device categorization: there are different electric devices contained in one

control cabinet, such as inverter, filter, PLC and instrument etc, which have different ability of emitting and withstanding electromagnetic noise. Therefore, it needs to categorize these devices into strong noise device and noise sensitive device. The same kinds of device should be placed in the same aream and the distance between devices of different category should be more than 20cm. Wire arrangement inside the control cabinet: thre are signal wire(light current) to make the power cable(strong current) in one cabinet. For the inverter, the power cables are categorized into input cable and output cable. Signal wires can be easily disturbed by power cables to make the equipment malfunction.

When wiring , signal cables and power cables should be arranged in different area. It is strictly prohibitive to arrange them in parallel or interlacement at a close distance (less than 20cm) or tie them together. If the signal wires have to cross the power cables, they should be arranged in 90 angles. Power input and output cables should not either be arranged in interlacement or tied together, especially when installed the EMC filter. Otherwise the distributed capacitances of its input and output power cable can be coupling each other to make the EMC filter out of function.

2.9.3.3

Inverter must be ground safely when in operation. Grounding enjoys priority in all EMC methods because it does not only ensure the safety of equipment and persons, but also is the simplest, most effective and lowest cost solution for EMC problems. Grounding has three categories: special pole grounding, common pole grounding and series-wound grounding. Different control system should use special pole grounding, and different devices in the same control system should use common pole grounding, and different devices connected by same power cable should use series-wound grounding.

2.9.3.4 Leakage current

Leakage current includes line-to-line leakage current and over-ground leakage current. Its value depends on distributed capacitances and carrier frequency of inverter. The over-ground leakage current, which is current passing through the common ground wire, can not only flow into inverter system but also other devices. It also can make leakage current circuit breaker, relay or other devices malfunction. The value of line-to-line leakage current, which means the leakage current passing through distributed capacitors of input output wire, depends on the carrier frequency of inverter, the length and section areas of motor cables. The higher carrier frequency of inverter, the longer of the motor cable and/or the bigger cable section area, the larger leakage current will occur. Countermeasure: decreasing the carrier frequency can effectively decrease the leakage current. In the case of motor cable is relatively long(longer than 50m), it is necessary to install AC reactor or sinusoidal wave filter at the output side, and when it is even longer, it is necessary to install one reactor at

every certain distance.

2.9.3.5 EMC filter

EMC filter has a great effect of electromagnetic decoupling, so it is preferred for customer to install it.

For inverter, noise filter has following categories:

Noise filter installed at the input side of inverter;

Install noise isolation for other equipment by means of isolation transformer or power filter.

2.9.4

When install inverter and EMI filter according to the operate manual and wiring, it can meet below requiremen:

EN61000-6-4: Pass electromagnetic interference test in industrial environment.

EN61800-3: Meet the require of the EN61800-3 electromagnetic radiation standard (II environment), If add EMC filter, it can meet the require of EN61000-6-3 electromagnetic radiation standard(Home environment) and EN61000-6-4 electromagnetic radiation standard (Industrial environment)

第三章 操作 Chapter 3 Operation





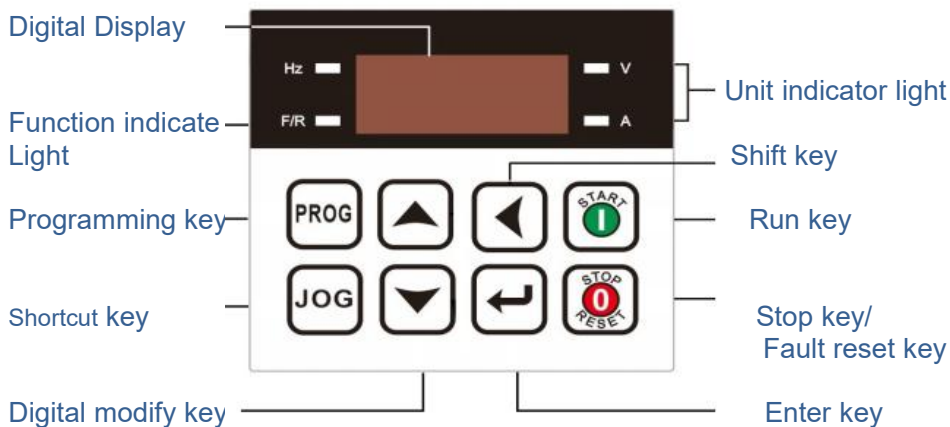





3.1 Keypad description

3.1.1



3.1 Operate panel diagram

3.1.2 Function Key description

Key	Name	Description
	Programming key	Entry or escape of first-level menu
	Enter key	Progressively enter menu and confirm parameters
	UP Increment Key	Increase data or function codes
	Down Decrement Key	Decrease data or function codes
	Shift Key	In parameter setting mode, press this button to select the bit to be modified. In the other modes, cyclically displays parameters by right shift
	Run Key	Start to run the inverter in keypad control mode
	Stop/Fault reset Key	In running status, restricted by F7.04, can be used to stop the inverter. When fault alarm, can be used to reset the inverter without any restriction.
	Shortcut Key	Determined by function code F7.03: 0: Display status switching 1: JOG operation 2: Switch between forward and reverse 3: Clear the UP/DOWN settings. 4: Quick debugging mode
 + 		Pressing the RUN and STOP/RST at the same time can achieve inverter coast to stop

3.1.3 Indicate light

Symbol	Description
Hz	Frequency Unit

F/R	Forward/Reverse indicator light: Light off indicate Forward status; Light on indicate Reverse status
V	Voltage Unit
A	Current Unit

3.2 Operation Process

3.2.1: Three levels of menu are:

- a. Function code group (First-level)
- b. Function code (Second-level)
- c. Function code value (Third-level)

Explanation: the three-level menu operation can press PRG or ENTTER to return to the secondary menu. The difference between the two menus are: press ENTER to set parameters in control panel, and then return to the secondary menu, and automatically move to the next function code; Press PRG directly to return to the secondary menu, don't store parameters, and keep staying in the current function code. Example: change the function code P1.04 from 00.00 Hz the sample set to 50.00 Hz.

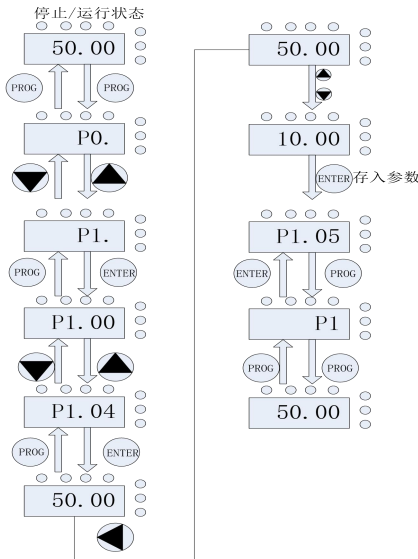

Third-level operation process

In three-level state, if the parameter is not flashing, means the function code cannot be modified, possible reasons are:

- 1) The function code parameters cannot be modified .Such as the actual testing parameters, operation records, etc.
- 2) The function code in the running state cannot be modified, need to stop to modify;

3.2.2

After the failure of the inverter, the inverter will prompt the related fault information. Users can press STOP key on the keyboard or terminal function to conduct the fault reset (P4), after fault reset, the inverter is in the standby state. If the inverter is in fault state, the user does not carry on the fault reset, the inverter is in the running to protect state, inverter can't run.

3.2.3 Motor parameter auto-tuning

Choosing no PG vector control operation mode, input motor nameplate parameters must be accurate, inverter will base on nameplate parameters matching standard motor; In order to get better control performance, motor parameter auto-tuning is suggested and auto-tuning steps are as follows:

First will run command channel choice (P0.02) choice for keyboard commands. Then the actual parameters according to the motor, please input the following parameters.

P1.01: the motor rated power;

P1.02: the motor rated voltage;

P1.03: the motor rated current;

P1.04: the motor rated frequency;

P1.05: the motor rated speed.

Note: in the process of auto-tuning , motor and load should be released, otherwise, the motor parameters obtained from the auto-tuning may not be correct.

The detail operate please refer to P1.37 description.

3.3 Running state

3.3.1 Power-on initialization

In the process of the Inverter's power-on, the system first initializes, LED display for "8000", and 7 lights are all bright. After the initialization is complete, the drive is in the standby mode.

3.3.2 Standby Status

In the stop or running status, can display a variety of state parameters. Select whether to display this parameter by Function Code P7.03 (operating parameters), P7.05 (stop parameter) binary bits, Various definitions can refer to P7.03 and P7.05 function code.

3.3.3

Motor parameters self-learning please refer to the detailed descriptions of P1.37 function code.

In the running state, a total of 14 status parameters can choose whether to display the status parameters : operating frequency, set frequency, bus voltage, output voltage, output current, running rotating speed, output frequency, output torque, PID setting, PID feedback, Switching value input status, NPN output status, analog input FIV voltage, Analog input FIC voltage, Multi-speed, torque setting value, whether to display the function code is decided by P7.03 bit (converted into binary) choice, press the key to switch the display order of the selected parameters, press the JOG key to switch in order to the selected display parameters.

3.3.5

Failure : inverter offers a variety of fault information, please refer T8000D series inverter faults and their countermeasures.

3.4 Quick commissioning

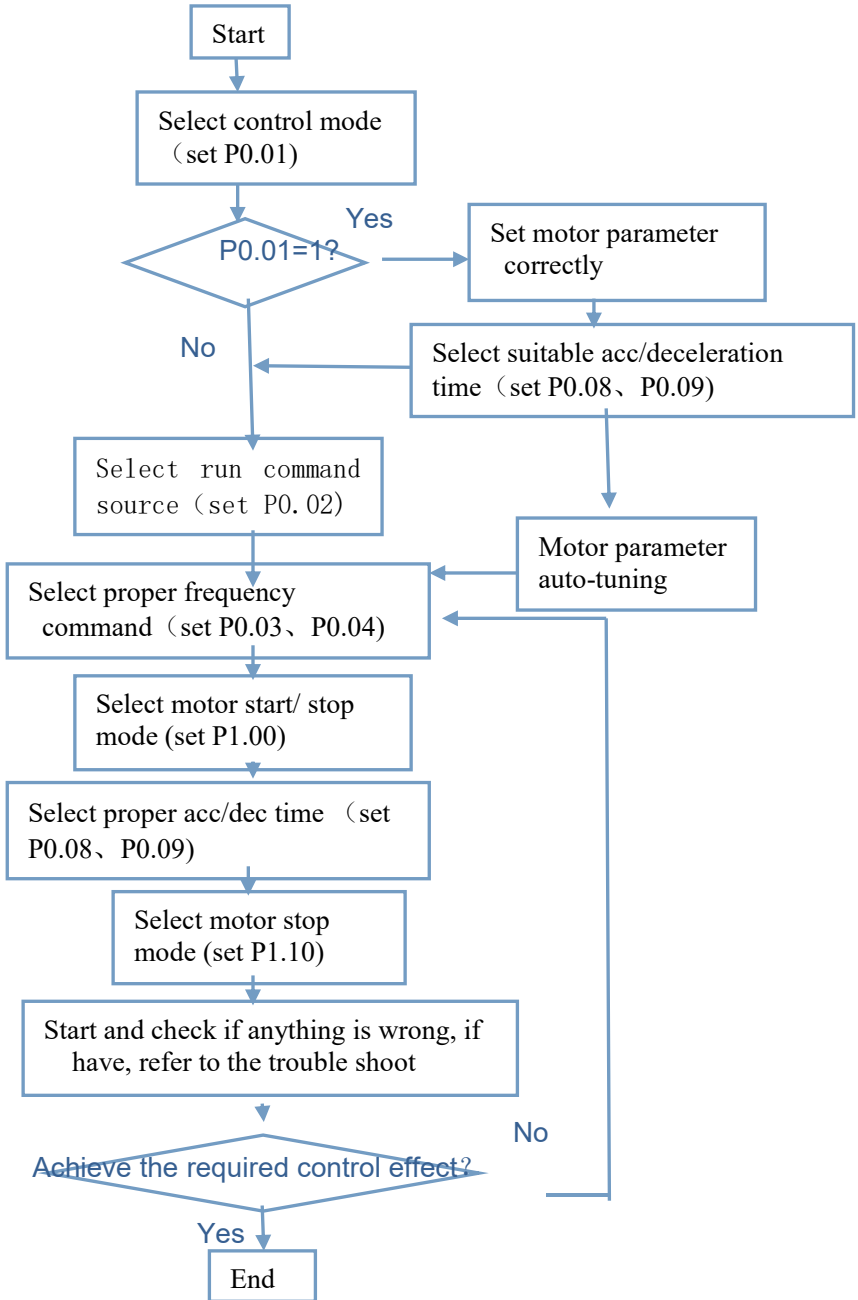

Chapter 4 Detailed Function Descriptions

Code	Name	Setting Range	Default	Property
Group P0:Standard Function Parameters				
P0.00	G/P type display	1: G type (Constant torque load) 2: P type (variable torque load e.g. fan and pump)	Model dependent	●
P0.01	Control Mode selection	0: sensorless vector control 1: Sensorless flux vector control 2: Voltage/Frequency (V/F) control	2	★
P0.02	Control Source selection	0: Operateion panel control (LED off) 1: Terminal control (LED on) 2: Communication control (LED linking)	0	☆
P0.03	Frequency source selection	0: Digital setting (P0.08 Preset frequency, can modify the UP/DOWN, power lost don' t memory) 1: Digital setting (P0.08 preset frequency, can modify the UP/DOWN, power lost memory) 2: FIV 3: FIC 4: Reserved 5: Pulse setting (X5) 6: Multistage instruction 7: Simple PLC 8: Reserved 9: Communication setting 10:Pluse synchronization	0	★
P0.04	Auxiliary frequency source Y selection	The same as P0.03 (Main frequency source X selection)	0	★

P0.05	Auxiliary frequency source superposition Y range selection	0: Relative to the maximum frequency 1: Relative to the main frequency source X	0	☆
P0.06	Auxiliary frequency source superposition Y range	0% ~ 150%	100%	☆

P0.07	Frequency source superposition selection	Unit's digit (Frequency source) 0: Main frequency source X 1: X and Y operation(operation relationship determined by ten's digit) 2: Switchover between X and Y 3: Switchover between X and "X and Y operation" 4: Switchover between Y and "X and Y operation" Ten's digit (X and Y operation) 0: X+Y 1: X-Y 2: Both the maximum 3: Both the minimum	00	☆
P0.08	Preset frequency	0.00Hz~ Maximum frequency (P0.10)	50.00Hz	☆
P0.09	Rotation direction	0: Same direction 1: Reverse direction	0	☆
P0.10	Maximum frequency	50.00Hz ~ 600.00Hz	50.00Hz	★
P0.11	Upper limit frequency source	0: P0.12 setting 1: FIV 2: FIC 3: Reserved 4: PULSE settings 5: communication settings 6: Multi-speed command	0	★

P0.12	Upper limit frequency	Frequency lower limit P0.14 ~ Maximum frequency P0.10	50.00Hz	☆
P0.13	Upper limit frequency offset	0.00Hz ~ Maximum frequency P0.10	0.00Hz	☆
P0.14	Lower limit frequency	0.00Hz ~ upper limit frequency P0.12	0.00Hz	☆
P0.15	Carrier frequency	0.8kHz ~ 16.0kHz	Model dependent	☆
P0.16	Carrier frequency adjustment with temperature	0: No 1: Yes	1	☆
P0.17	Acceleration time	0.00s ~ 65000s	3.00s	☆
P0.18	Deceleration time	0.00s ~ 65000s	3.50s	☆
P0.19	Acceleration/Deceleration time unit	0: 1s 1: 0.1s 2: 0.01s	1	★
P0.21	Frequency offset of auxiliary frequency source for X and Y operation	0.00Hz ~ Maximum frequency P0.10	0.00Hz	☆
P0.22	Frequency reference	1: 0.1Hz 2: 0.01Hz	2	★
P0.25	Acceleration/Deceleration time base frequency	0: Maximum frequency (P0.10) 1: Set frequency 2: 100Hz	0	★
P0.26	frequency for UP/DOWN modification during running	0: Running frequency 1: Setting frequency	0	★

P0.27	Binding command source to frequency source	Unit's digit: Binding operation panel command to frequency source 0: No binding 1: Frequency source by digital setting 2: FIV 3: FIC 4: Reserved 5: Pulse setting (X5) 6: Multi-Speed 7: Simple PLC 8: PID 9: Communication setting Ten's digit: Binding terminal command to frequency source selection Hundred's digit: Binding communication command to frequency source selection Thousand's digit: Auto binding frequency source selection	0000	☆
Group P1 Motor parameter				
	Motor type selection	0: Common asynchronous motor 1: Spindle asynchronous motor 2. Permanent Magnet Synchronous motor	1	★
P1.01	Rated motor power	0.1kW ~ 1000.0kW	Motor dependent	★

P1.02	Rated motor voltage	1V ~ 2000V	Motor dependent	★
P1.03	Rated motor current	0.01A ~ 655.35A(AC drive power ≤ 55kW) 0.1A ~ 6553.5A(AC drive power >55kW)	Motor dependent	★
P1.04	Rated motor frequency	0.01Hz ~ maximum frequency	Motor dependent	★
P1.05	Rated motor rotational speed	1rpm ~ 65535rpm	Motor dependent	★
P1.06	Stator resistance (asynchronous motor)	0.001Ω ~ 65.535Ω(AC Drive power ≤ 55kW) 0.0001Ω ~ 6.5535Ω(AC Drive power >55kW)	Tuned parameter	★
P1.07	Rotor resistance (asynchronous motor)	0.001Ω ~ 65.535Ω(AC Drive power ≤ 55kW) 0.0001Ω ~ 6.5535Ω(AC Drive power >55kW)	Tuned parameter	★
P1.08	Leakage inductive reactance (asynchronous motor)	0.01mH ~ 655.35mH(AC drive power ≤ 55kW) 0.001mH ~ 65.535mH(AC drive power >55kW)	Tuned parameter	★
P1.09	Mutual inductive reactance (asynchronous motor)	0.1mH ~ 6553.5mH(AC drive power ≤ 55kW) 0.01mH ~ 655.35mH(AC drive power >55kW)	Tuned parameter	★
P1.10	No-load current (synchronous motor)	0.01A ~ P1.03(AC Drive power ≤ 55kW) 0.1A ~ P1.03(AC Drive power >55kW)	Tuned parameter	★

P1.11	synchronous motor core saturation coefficient 1	50.0%~100.0%	86.0%	★
P1.12	synchronous motor core saturation coefficient 2	100.0%~150.0%	130.0%	★
P1.13	synchronous motor core saturation coefficient 3	100.0%~170.0%	140.0%	★
P1.14	synchronous motor core saturation coefficient 4	100.0%~180.0%	150.0%	★
P1.15	synchronous motor tuned parameter reserve 1	0~65535	0	★
P1.16	synchronous motor tuned parameter reserve 2	0~65535	0	★

P1.17	Shaft D inductance (synchronous motor)	0.01mH ~ 655.35mH(AC Drive power ≤ 55kW) 0.001mH ~ 65.535mH(AC Drive power >55kW)	Auto tuning	★
P1.18	Shaft Q inductance (synchronous motor)	0.01mH ~ 655.35mH(AC Drive power ≤ 55kW) 0.001mH ~ 65.535mH(AC Drive power >55kW)	Auto tuning	★
P1.19	Factory parameter	0~65535	0	★
P1.20	Back EMF (synchronous motor)	0.1V ~ 6553.5V	Auto tuning	★
P1.21	Factory parameter	0~65535	0	★
P1.22	Torque inertia ratio	0.01~10.00	1.00	★
P1.23	Percentage of friction torque	0.00%~100.00%	0.00%	★
P1.24	Factory parameter	0~65535	0	★
P1.25	Factory parameter	0~65535	0	★
P1.26	Factory parameter	0~65535	0	★
P1.27	Encoder pulses per revolution	1 ~ 20000	1024	★
		0: ABZ incremental encoder		

P1.28	Encoder type	1:UVW incremental encoder 2: Resolver 3: SIN/COS encoder 4: Wire-saving UVW encoder	0	★
P1.29	Factory parameter	0~65535	0	
P1.30	Encoder wire code	BIT0: AB signal direction or rotate direction BIT1: Absolute position direction (UVW or SIN/COS encoder's C D signal)	0	★
P1.31	Encoder zero point position angle	0.0 ~ 359.9°	0.0°	★
P1.32	Motor gear ratio molecule	1~65535	1	★
P1.33	Motor gear ratio denominator	1~65535	1	★
P1.34	Rotation pole logarithm	1~32	1	★
P1.35	Factory parameter	0~65535	0	★
P1.36	Speed feedback PG card break line detection time	0.0: No action 0.1s ~ 10.0s	0.0s	★
P1.37	Auto tuning selection	0: No operation 1:Asynchronous motor static auto-tuning 2: Asynchronous motor auto-tuning 3:Asynchronous motor dynamic parameters auto-tuning	0	★
P2.00	Low-speed speed loop Kp	1 ~ 200	40	☆
P2.01	Low-speed speed loop Ti	0.001s ~ 10.000s	0.500s	☆
P2.02	Switch frequency 1	0.00 ~ P2.05	5.00Hz	★
P2.03	High-speed speed loop Kp	1 ~ 200	30	☆
P2.04	High-speed speed loop Ti	0.001s ~ 10.000s	0.500s	☆
P2.05	Switchover frequency 2	P2.02~Maximum frequency	10.00Hz	★

P2.06	Vector rotation compensation adjustment	50% ~ 200%	100%	☆
P2.07	Speed feedback filter time	0.000s ~ 0.100s	0.000s	☆
P2.09	Torque upper limit source in speed control mode(electrical)	0: P2.10 1: FIV 2: FIC 3: Reserved 4: Pulse setting 5: Communication setting 6: MIN(FIV,FIC) 7: MAX (FIV,FIC) 1-7 Full range response to P2.10	0	★
P2.10	Torque upper limit setting in speed control mode (electrical)	0.0% ~ 200.0%	150.0%	★
P2.11	Torque upper source in speed control mode (generation)	Refer to P2.09	0	★
P2.12	Torque upper limit setting in speed control mode(generation)	0.0% ~ 200.0%	150.0%	☆
P2.13	Low-speed current loop Kp adjustment	0.1 ~ 10.0	1.0	☆
P2.14	Low-speed current loop Ki adjustment	0.1 ~ 10.0	1.0	☆
P2.15	High-speed current loop Kp adjustment	0.1 ~ 10.0	1.0	☆
P2.16	High-speed current loop Ki adjustment	0.1 ~ 10.0	1.0	☆
P2.17	Kp Zero speed lock speed loop Kp	1 ~ 100	30	☆
P2.18	Zero speed lock speed loop Ti	0.001s ~ 10.000s	0.500s	☆
P2.20	Zero speed lock speed loop switchover frequency	0.00 ~ P2.02	0.20Hz	★
P3.00	V/F curve setting	0: Linear V/F 1: Multi-point V/F 2: Square V/F 3: 1.2-power V/F 4: 1.4-power V/F 6: 1.6-power V/F 8: 1.8-power V/F	0	★
P3.01	Torque boost	0.0%: (fixed torque boost) 0.1% ~ 30.0%	Model dependent	☆

P3.02	Cut-off frequency of torque boost	0.00Hz~ Maximum frequency	50.00Hz	★
P3.03	Multi-point VF frequency 1	0.00Hz ~ P3.05	0.00Hz	★
P3.04	Multi-point voltage 1	0.0% ~ 100.0%	0.0%	★
P3.05	Multi-point VF frequency 2	P3.03 ~ P3.07	0.00Hz	★
P3.06	Multi-point voltage 2	0.0% ~ 100.0%	0.0%	★
P3.07	Multi-point VF frequency 3	P3.05~rated motor frequency (P1.04)	0.00Hz	★
P3.08	Multi-point VF voltage 3	0.0% ~ 100.0%	0.0%	★

P3.09	V/F slip compensation gain	0.0% ~ 200.0%	0.0%	★
P3.10	V/F over-excitation gain	0 ~ 200	0	★
P3.11	V/F oscillation suppression gain	0 ~ 100	Model dependent	★
P3.12	V/F control parameter reserve	0~65535	0	★
P3.16	V/F Over current lost speed	0: Disabled 1: Enabled	1	★
P3.17	V/F over current lost speed current	100%~180%	150%	★
P3.18	V/F over current lost speed gain	0~100	30	★
P3.19	V/F triple-speed suppression of action current compensation coefficient	50%~150%	50%	★
P3.20	Bus over voltage lost speed	0: Disabled 1: Enabled	1	★

P3.21	Bus voltage lost speed voltage (braking resistor opening voltage)	120%~150%	120%	★
P3.22	Bus over voltage lost speed gain Kp	0~500	300	★
P3.23	Bus over voltage lost speed gain Ki	0~100	50	★
P3.24	Bus over voltage lost speed frequency increase limit	0.0~30.0Hz	5.0Hz	★

Group P4 Input terminal				
P4.00	x1 function selection	0: No function 1: Forward RUN (FWD) 2: Reverse RUN (REV) 3: Three-line control 4: Forward JOG (JOG-F) 5: Reverse JOG (JOG-R) 6: Terminal UP 7: Terminal DOWN 8: Coast to stop 9: Fault reset (RESET)	1	★
P4.01	x2 function selection	10: RUN pause 11: Normally open (NO) input of external fault 12: Multi-Reference terminal 1 13: Multi-Reference terminal 2 14: Multi-Reference terminal 3 15: Multi-Reference terminal 4 16: Terminal 1 for acceleration/ deceleration time selection 17: Terminal 2 for acceleration/ deceleration time selection	2	★
P4.02	X3 function selection	18: Frequency source Switchover 19: UP and DOWN setting clear (terminal, operation)	64	★
P4.03	X4 function selection		65	★
P4.04	X5 function selection		50	★

P4.05	X6 function selection	panel) 20: Command source switchover terminal 21: Acceleration/Deceleration Prohibited 22: PID pause	0	★
P4.06	X7 function selection	23: PLC status reset 24: Swing pause 25: Counter input 26: Counter reset 27: Length count input	0	★
P4.07	X8 function selection	28: Length reset 29: Torque control prohibited 30: Pulse frequency input (enabled only for X5)	0	★
P4.08	Reserved	31: Reserved 32: Immediate DC braking 33: Normally closed (NC) input of external fault	0	★
P4.09	保留 RESERVED	34: Frequency modification enable 35: Reverse PID action direction 36: External STOP terminal 1 37: Command source switchover terminal 2 38: PID integral pause 39: Switchover between main frequency source X and preset frequency 40: Switchover between auxiliary frequency source Y and preset frequency 41: Motor terminal selection 1 42: Motor terminal selection 2 43: PID parameter switchover 44: User-defined fault 1 45: User-defined fault 2 46: Speed control/Torque control switchover 47: Emergency stop 48: External STOP terminal 2 49: Deceleration DC braking 50: Clear the current running time 51-59:Reserved 64: Pulse synchronous mode switchover (Pulse speed synchronization<-> Pulse position synchronization) 65: Location control switchover (no command) 66: locaion control switch (with FWD command)	0	★

--	--	--	--	--

P4.10	X filter time	0.000s ~ 1.000s	0.010s	☆
P4.11	Terminal command mode	0: Two-line mode 1 1: Two-line mode 2 2: Three-line mode 1 3: Three-line mode 2	0	★
P4.12	Terminal UP/DOWN rate	0.001Hz/s ~ 65.535Hz/s	1.00Hz/s	☆
P4.13	FI curve 1 minimum input	-10.00V ~ P4.15	-10.00V	☆

P4.14	Corresponding setting of FI curve 1 minimum input	-100.0% ~ +100.0%	-100.0%	☆
P4.15	FI curve 1 maximum input	P4.13 ~ +10.00V	10.00V	☆
P4.16	Corresponding setting of FI curve 1 maximum input	-100.0% ~ +100.0%	100.0%	☆
P4.17	FIV curve 1 filter time	0.00s ~ 10.00s	0.10s	☆
P4.18	FI curve 2 minimum input	0.00V ~ P4.20	0.00V	☆
P4.19	Corresponding setting of FI curve 2 minimum input	-100.0% ~ +100.0%	0.0%	☆
P4.20	FI curve 2 maximum input	P4.18 ~ +10.00V	10.00V	☆
P4.21	Corresponding setting of FI curve 2 maximum input	-100.0% ~ +100.0%	100.0%	☆
P4.22	FIC filter time	0.00s ~ 10.00s	0.10s	☆
P4.23	FI curve 3 minimum input	-10.00V ~ P4.25	-10.00V	☆
P4.24	Corresponding setting of FI curve 3 minimum input	-100.0% ~ +100.0%	-100.0%	☆
P4.25	FI curve 3 maximum input	P4.23 ~ +10.00V	10.00V	☆
P4.26	Corresponding setting of FI curve 3 maximum input	-100.0% ~ +100.0%	100.0%	☆
P4.27	Reserved	0.00s ~ 10.00s	0.10s	☆

P4.28	PULSE minimum input	0.00kHz ~ P4.30	0.00kHz	☆
P4.29	Corresponding setting of pulse minimum input	-100.0% ~ 100.0%	0.0%	☆
P4.30	PULSE maximum input	P4.28 ~ 100.00kHz	50.00kHz	☆
P4.31	PULSE maximum input setting	-100.0% ~ 100.0%	100.0%	☆
P4.32	PULSE filter time	0.00s ~ 10.00s	0.10s	☆

P4.33	FI curve selection	Unit's digit: FIV curve selection 1: Curve 1 (2 points, see P4.13~P4.16) 2: Curve 2 (2 points, see P4.18~P4.21) 3: Curve 3 (2 points, see P4.23~P4.26) 4: Curve 4 (4 points, see L6.00~L6.07) 5: Curve 5 (4 points, see L6.08~L6.15) Ten's digit: FIC curve selection (1~5, same as FIV) Hundred's digit: Reserved	321	☆
P4.34	Setting selection for FI less than minimum input	Unit's digit: Setting for FIV less than minimum input 0: Corresponds to the minimum input settings 1: 0.0% Ten's digit: Setting selection for FIC less than minimum input (0~1, same as FIV)	000	☆
P4.35	X1 delay time	0.0s ~ 3600.0s	0.0s	★
P4.36	X2 delay time	0.0s ~ 3600.0s	0.0s	★
P4.37	X3 delay time	0.0s ~ 3600.0s	0.0s	★

P4.38	X valid mode selection 1	0: High level valid 1: Low level valid Unit's digit: X1 Ten's digit: X2 Hundred's digit: X3 Thousand's digit: X4 Ten thousand's digit: X5	00000	★
P4.39	X valid mode selection 2	0: High level valid 1: Low level valid Unit's digit: X6 Ten's digit: X7 Hundred's digit: X8	00000	★

Group P5 Output terminals				
P5.00	Y0 terminal output mode selection	0: Pulse output (Y0P) 1: Switch signal output(Y0R)	1	☆
P5.01	Y0R output function selection	0: No output 1: Servo drive running 2: Fault output (stop) 3: Frequency-level detection FDT1 output 4: Frequency reached 5: Zero-speed running(no output at stop) 6: Motor overload pre-warning 7: servo drive overload pre-warning 8: Setting count value Reached 9: Designated count value reached 10: Length reached 11: PLC cycle complete 12: Accumulative running time reached 13: Frequency limited 14: Torque limited 15: Ready for RUN 16: FIV>FIC 17: Frequency upper limit reached 18: Frequency lower limit reached (no output at stop) 19: Under voltage state output 20: Communication setting 21: Positioning completed (Reserved) 22: Positioning closed (Reserved) 23: Zero-speed running 2 (having output at stop) 24: Accumulative power-on time reached 25: Frequency level detection FDT2 output 26: Frequency 1 reached output 27: Frequency 2 reached output 28: Current 1 reached output 29: Current 2 reached output 30: Timing reached output 31: FIV input limit exceeded 32: Load becoming 0 33: Reverse running 34: Zero current state 35: Module temperature reached 36: Output current limit exceeded 37: Frequency lower limit reached (having output at stop) 38: Alarm output(Keep running) 40: Current running time reached 41:location zero point search complete 42:Incremental location complete(500ms high electrical level) 43 Absolute l location complete(500ms high electrical level) 44::Indexing location complete(500ms high electrical level)	4	☆
P5.02	Relay function selection (YA-YB-YC)		2	☆
P5.03	Reserved		0	☆
P5.04	Control board reply output function selection (RA-RB-RC)		21	☆
P5.05	Reserved		4	☆

P5.06	Y0P output function selection	0: Running frequency 1: Setting frequency 2: Output current 3: Output torque 4: Output power 5: Output voltage 6: Pulse input (100.0% for 100.0kHz)	0	☆
P5.07	FOV output function selection	7: FIV 8: FIC 9: Reserved (Expansion card) 10: Length 11: Count value 12: Communication setting	0	☆
P5.08	FOC output function selection	13: Motor rotational speed 14: Output current (100.0% for 1000.0A) 15: Output voltage (100.0% for 1000.0V) 16: Reserved	1	☆
P5.09	Y0P output maximum frequency	0.01kHz ~ 100.00kHz	50.00kHz	☆
P5.10	FOV bias coefficient	-100.0% ~ +100.0%	0.0%	☆
P5.11	FOV gain	-10.00 ~ +10.00	1.00	☆
P5.12	FOC bias coefficient	-100.0% ~ +100.0%	0.0%	☆
P5.13	FOC gain	-10.00 ~ +10.00	1.00	☆
P5.17	Y0R output delay time	0.0s ~ 3600.0s	0.0s	☆
P5.18	YA-YB-YC output delay time	0.0s ~ 3600.0s	0.0s	☆
P5.19	Reserved	0.0s ~ 3600.0s	0.0s	☆
P5.20	RA-RB-RC 输出延迟时间 RA-RB-RC output delay time	0.0s ~ 3600.0s	0.0s	☆
P5.21	保留 Reserved	0.0s ~ 3600.0s	0.0s	☆

P5.22	Output terminal valid mode selection	0: Positive logic 1: Negative logic Unit's digit: Y0R Ten's digit: YA-YB-YC Hundred's digit: RA-RB-RC	00000	☆
Group P6 Start/Stop control				
P6.00	V/F start mode	0: direct start 1: Rotational speed tracking restart 2: Pre-excited start (asynchronous motor vector)	0	★
P6.01	Use start pre-torque selection	0: No 1: YES	0	★
P6.02	Start pre-torque setting	0.0%~200.0%	0.0%	★
P6.03	Start frequency	0.00Hz ~ 10.00Hz	0.00Hz	☆

P6.04	Startup frequency holding time	0.0s ~ 100.0s	0.0s	★
P6.05	Startup DC braking current/Pre-excited current	0% ~ 100%	0%	★
P6.06	Startup DC braking time/Pre-excited time	0.0s ~ 100.0s	0.0s	★
P6.10	Stop mode	0: Decelerate to stop 1: Coast to stop	0	☆
P6.11	Initial frequency of stop DC braking	0.00Hz ~Maximum frequency	0.00Hz	☆

P6.12	Waiting time of stop DC braking	0.0s ~ 100.0s	0.0s	☆
P6.13	Stop DC braking current	0% ~ 100%	0%	☆
P6.14	Stop DC braking time	0.0s ~ 100.0s	0.0s	☆
P6.15	Brake use ratio	0% ~ 100%	100%	☆
Group P7: Operation Panel and Display				
P7.01	JOG key function selection	0: JOG key disabled 1: Switchover between operation panel change and remote command channel (terminal command channel or communication command channel) 2: Switchover between FWD and REV 3: FWD JOG 4: REV JOG	0	★
P7.02	STOP/RESET key function	0:STOP/RESET key enabled only in operation panel control 1:STOP/RESET key enabled in any operation mode	0	☆

P7.03	LED display running parameter 1	0000 - FFFF Bit00: Running frequency 1 (Hz) Bit01: Setting frequency (Hz) Bit02: Bus voltage (V) Bit03: Output voltage (V) Bit04: Output current (A) Bit05: Output power (kW) Bit06: Output torque (%) Bit07: X input status Bit08: YO output status Bit09: FIV voltage (V) Bit10: FIC voltage (V) Bit11: Reserved Bit12: Count value Bit13: Length value Bit14: Load speed display Bit15: PID setting	1F	☆
-------	---------------------------------	--	----	---

P7.04	LED display running parameter 2	Bit00: PID feedback Bit01: PLC stage Bit02: Pulse input frequency(kHz) Bit03: Running frequency 2 (Hz) Bit04: Remaining running time Bit05: FIV voltage before correction (V) Bit06: FIC voltage before correction (V) Bit07: Reserved Bit08: Linear speed Bit09: Current power-on time(Hour) Bit10: Current running time (Min) Bit11: Pulse input frequency(Hz) Bit12: Communication setting value Bit13: Reserved Bit14: Main frequency X display(Hz) Bit15:Auxiliary frequency Y display (Hz)	0	☆
P7.05	LED display stop parameter	0000 - FFFF Bit00: Set frequency (Hz) Bit01: Bus voltage (V) Bit02: X input status Bit03: YO output status Bit04: FIV voltage (V) Bit05: FIC voltage (V) Bit06: Reserved Bit07: Count value Bit08: Length value Bit09: PLC stage Bit10: Load speed Bit11: PID setting Bit12: Pulse setting frequency(kHz)	33	☆
P7.06	Load speed display coefficient	0.0001 ~ 6.5000	1.0000	☆

P7.07	Heatsink temperature of inverter IGBT	0.0°C ~ 100.0°C	-	●
P7.08	Heatsink Temperature of rectifier bridge	0.0°C ~ 100.0°C	-	●
P7.09	Accumulative running time	0h ~ 65535h	-	●
P7.10	Temporary software version	-	-	●
P7.11	Software version	-	-	●
P7.12	Numbers of decimal places for load speed display	0: 0 decimal place 1: 1 decimal place 2: 2 decimal places 3: 3 decimal places	1	☆
P7.13	Accumulative power-on time	0h ~ 65535h	-	●
P7.14	Accumulative power consumption	0Kw ~ 65535	-	●

Group P8: Auxiliary Functions

P8.00	JOG running frequency	0.00Hz ~ maximum frequency	2.00Hz	☆
P8.01	JOG acceleration time	0.0s ~ 6500.0s	20.0s	☆
P8.02	JOG deceleration time	0.0s ~ 6500.0s	20.0s	☆
P8.03	Acceleration time 2	0.0s ~ 6500.0s	Model dependent	☆
P8.04	Deceleration time 2	0.0s ~ 6500.0s	Model	☆

			depend ent	
P8.05	Acceleration time 3	0.0s ~ 6500.0s	Model depend ent	☆
P8.06	Deceleration time 3	0.0s ~ 6500.0s	Model depend ent	☆
P8.07	Acceleration time 4	0.0s ~ 6500.0s	Model depend ent	☆
P8.08	Deceleration time 4	0.0s ~ 6500.0s	Model depend ent	☆
P8.09	Jump frequency 1	0.00Hz ~ maximum frequency	0.00Hz	☆
P8.10	Jump frequency 2	0.00Hz ~ maximum frequency	0.00Hz	☆
P8.11	Frequency jump amplitude	0.00Hz ~ maximum frequency	0.01Hz	☆
P8.12	Forward/Reverse rotation dead-zone time	0.0s ~ 3000.0s	0.0s	☆
P8.13	Reverse control	0: Enabled 1: Disabled	0	☆
P8.14	Running mode when set frequency lower than frequency lower limit	0: Run at frequency lower limit 1: Stop 2: Run at zero speed	0	☆
P8.15	Droop control	0.00Hz ~ 10.00Hz	0.00Hz	☆
P8.16	Accumulative power-on time threshold	0h ~ 65000h	0h	☆

P8.17	Accumulative running time threshold	0h ~ 65000h	0h	☆
P8.18	Startup protection	0: Not protect 1: Protect	0	☆
P8.19	Frequency detection value (FDT1)	0.00Hz ~ maximum frequency	50.00Hz	☆
P8.20	Frequency detection hysteresis (FDT1)	0.0% ~ 100.0% (FDT1 level)	5.0%	☆
P8.21	Detection range of frequency reached	0.0% ~ 100.0% (maximum frequency)	0.0%	☆
P8.22	Jump frequency during acceleration/ deceleration	0: Disabled 1: Enabled	0	☆
P8.25	Frequency switchover point between acceleration time 1 and acceleration time 2	0.00Hz ~ maximum frequency	0.00Hz	☆
P8.26	Frequency switchover point between deceleration time 1 and deceleration time 2	0.00Hz ~ maximum frequency	0.00Hz	☆
P8.27	Terminal JOG preferred	0: Disabled 1: Enabled	0	☆
P8.28	Frequency detection value (FDT2)	0.00Hz ~ maximum frequency	50.00Hz	☆
P8.29	Frequency detection hysteresis (FDT2)	0.0% ~ 100.0% (FDT2 level)	5.0%	☆
P8.30	Any frequency reaching detection value 1	0.00Hz ~ maximum frequency	50.00Hz	☆

P8.31	Any frequency reaching detection amplitude 1	0.0%~100.0% (maximum frequency)	0.0%	☆
P8.32	Any frequency reaching detection value 2	0.00Hz~maximum frequency	50.00Hz	☆
P8.33	Any frequency reaching detection amplitude 2	0.0%~100.0% (maximum frequency)	0.0%	☆

P8.34	Zero current detection level	0.0%~300.0% 100.0% for rated motor current	5.0%	☆
P8.35	Zero current detection delay time	0.01s ~ 600.00s	0.10s	☆
P8.36	Output over-current threshold	0.0% (no detection) 0.1%~300.0% (rated motor current)	200.0%	☆
P8.37	Output over-current detection delay time	0.00s ~ 600.00s	0.00s	☆
P8.38	Any current reaching 1	0.0%~300.0% (rated motor current)	100.0%	☆
P8.39	Any current reaching 1 amplitude	0.0%~300.0% (rated motor current)	0.0%	☆
P8.40	Any current reaching 2	0.0%~300.0% (rated motor current)	100.0%	☆
P8.41	Any current reaching 2 amplitude	0.0%~300.0% (rated motor current)	0.0%	☆
P8.42	Timing function selection	0:Disabled 1:Enabled	0	☆

P8.43	Timing duration source	0: P8.44 1: FIV 2: FIC 100% of analog input corresponds to the value of P8.44	0	☆
P8.44	Timing duration	0.0Min ~ 6500.0Min	0.0Min	☆
P8.45	FIV input voltage lower limit protection value	0.00V ~ P8.46	3.10V	☆
P8.46	FIV input voltage upper limit protection value	P8.45 ~ 10.00V	6.80V	☆
P8.47	Module temperature threshold	0℃ ~ 100℃	75℃	☆
P8.48	Cooling fan control	0: Fan working during running 1: Fan working continuously	0	☆
P8.49	Wakeup frequency	Dormant frequency (P8.51) ~ maximum frequency (P0.10)	0.00Hz	☆
P8.50	Wakeup delay time	0.0s ~ 6500.0s	0.0s	☆
P8.51	Dormant frequency	0.00Hz ~ wakeup frequency (P8.49)	0.00Hz	☆
P8.52	Dormant delay time	0.0s ~ 6500.0s	0.0s	☆
P8.53	Current running time reached	0.0Min ~ 6500.0Min	0.0Min	☆
P8.54	Current running time reached setting	0.00% ~ 100.00%	100.00%	☆

Group P9: Fault and Protection

P9.00	Motor overload protection selection	0: Disabled 1: Enabled	1	☆
P9.01	Motor overload protection gain	0.20 ~ 10.00	1.00	☆
P9.02	Motor overload warning coefficient	50% ~ 100%	80%	☆
P9.03	Fault control	0~65535(按 BIT control program)	0	☆
P9.04	Software over voltage setting (adjust parameter)	10%~100%	100%	☆
P9.05	Software over current setting (adjust parameter)	5%~100%	100%	☆
P9.06	Output phase lost detection selection before startup	0: disabled 1: enabled	0	★

P9.07	Short-circuit to ground upon power on	0: Disabled 1: Enabled	1	★
P9.09	Fault auto reset times	0 ~ 20	0	☆
P9.10	YO action selection during fault auto reset	0: No act 1: Act	0	☆
P9.11	Time interval of fault auto reset	0.1s ~ 100.0s	1.0s	☆
P9.12	Input phase lost/contactors suction protection selection	Unit's digit: Input phase lost protection Ten's digit: contactors suction protection 0: disabled 1: enabled	11	☆

P9.13	Output phase loss protection selection	0: Disabled 1: Enabled	1	☆
P9.14	1st fault type	0: No fault 1: Reserved 2: Over-current during acceleration 3: Over-current during deceleration 4: Over-current at constant speed 5: Over-voltage during acceleration 6: Over-voltage during deceleration 7: Over-voltage at constant speed 8: Over-load of butter resistance 9: Undervoltage 10: Servo drive overload 11: Motor overload 12: Input Phase lost 13: Power output phase loss 14: Module overheat 15: External equipment fault 16: Communication fault 17: Contactor fault 18: Current detection fault 19: Motor auto-tuning fault 20: Encoder/PG card fault 21: Parameters read-write fault 22: Servo drive hardware fault 23: Short circuit to ground 24: Reserved 25: Reserved 26: Accumulative running time reached 27: User-defined fault 1 28: User-defined fault 2 29: Accumulative power-on time reached 30: Load becoming 0 31: PID feedback lost during running 40: Fast limit overtime 42: Speed deviation too large 43: Motor over speed 51: Initial position fault 54: Zero point lost 55: Pluse deviation too large	—	●
P9.15	2nd fault type		—	●
P9.16	3rd (latest) fault type		—	●
P9.17	Frequency upon 3rd(latest) fault		—	●

P9.18	Current upon 3rd (latest) fault	–	–	●
P9.19	Bus voltage upon 3rd(latest) fault	–	–	●
P9.20	Input terminal status upon 3rd(latest) fault	–	–	●
P9.21	Output terminal status upon 3rd (latest) fault	–	–	●
P9.22	Servo drive status upon 3rd(latest) fault	–	–	●
P9.23	Power-on time upon 3rd (latest) fault	–	–	●
P9.24	Running time upon 3rd (latest) fault	–	–	●
P9.27	Frequency upon 2nd fault	–	–	●
P9.28	Current upon 2 nd fault	–	–	●
P9.29	Bus voltage upon 2nd fault	–	–	●
P9.30	Input terminal status upon 2nd fault	–	–	●
P9.31	Output terminal status upon 2nd fault	–	–	●

P9.32	Servo drive status upon 2nd fault	—	—	●
P9.33	Power-on time upon 2nd fault	—	—	●
P9.34	Running time upon 2nd fault	—	—	●
P9.37	Frequency upon 1st fault	—	—	●
P9.38	Current upon 1st fault	—	—	●
P9.39	Bus voltage upon 1st fault	—	—	●
P9.40	Input terminal status upon 1st fault	—	—	●
P9.41	Output terminal status upon 1st fault	—	—	●
P9.42	Frequency status upon 1st fault	—	—	●
P9.43	Power-on time upon 1st fault	—	—	●
P9.44	Running time upon 1st fault	—	—	●

P9.47	Fault protection action selection 1	Unit's digit: Motor overload (OL1) 0: Coast to stop 1: Stop according to the stop mode 2: Continue to run Ten's digit: Reserved Hundred's digit: Power output phase loss (LO) Thousand's digit: External equipment fault (EF) Ten thousand's digit: Communication fault (CE)	00000	☆
P9.48	Fault protection action selection 2	Unit's digit: Encoder/PG card fault (PG) 0: Coast to stop Ten's digit: Function code read-write fault (EEP) 0: Coast to stop 1: Stop according to the stop mode Hundred's digit: Reserved Thousand's digit: Reserved Ten thousand's digit: Accumulative running time reached (END1)	00000	☆

P9.49	Fault protection action selection 3	Unit's digit: Reserved Ten's digit: Reserved Hundred's digit: Accumulative running time reached (END2) 0: Coast to stop 1: Stop according to the stop mode 2: Continue to run	00000	☆
P9.50	Fault protection action selection 4	Unit's digit: Speed deviation too large (ESP) 0: Coast to stop 1: Stop according to the stop mode 2: Continue to run Ten's digit: Motor over speed (OSP) Thousand's digit: Reserved	00000	☆
P9.54	Frequency selection for continuing to run	0: Current running frequency 1: Set frequency 2: Frequency upper limit 3: Frequency lower limit 4: Backup frequency upon abnormality	0	☆
P9.55	Backup frequency upon abnormality	(100.0% corresponds to the maximum frequency P0.12)	100.0%	☆

P9.59	Action selection at instantaneous power failure	0: Invalid 1: Decelerate 2: Decelerate to stop	0	☆
P9.60	Reserved	P9.62 ~ 100.0%	100.0%	☆

P9.61	Voltage rally judging time at instantaneous power failure	0.00s ~ 100.00s	0.50s	☆
P9.62	Action judging voltage at instantaneous power	60.0%~100.0% (standard bus voltage)	80.0%	☆
P9.67	Over speed detection value	0.0 % ~ 50.0 % (Maximum frequency) (when 0.0% cancel)	5.0%	☆
P9.68	Over speed detection time	0.0s ~ 60.0s	1.0s	☆
P9.69	Detection value of too large speed deviation	0.0 % ~ 50.0 % (Maximum frequency) (when 0.0% cancel)	0.0%	☆
P9.70	Detection time of too large speed deviation	0.0s ~ 60.0s	0.0s	☆

Group Pb: Swing Frequency, Fixed Length and Count

Pb.00	Swing frequency setting mode	0: Relative to the central frequency 1: Relative to the maximum frequency	0	☆
Pb.01	Swing frequency amplitude	0.0% ~ 100.0%	0.0%	☆

Pb.02	Jump frequency amplitude	0.0% ~ 50.0%	0.0%	☆
Pb.03	Swing frequency cycle	0.1s ~ 3000.0s	10.0s	☆
Pb.04	Triangular wave rising time coefficient	0.1% ~ 100.0%	50.0%	☆
Pb.05	Set length	0m ~ 65535m	1000m	☆
Pb.06	Actual length	0m ~ 65535m	0m	☆
Pb.07	Number of pulses per meter	0.1 ~ 6553.5	100.0	☆
Pb.08	Set count value	1 ~ 65535	1000	☆
Pb.09	Designated count value	1 ~ 65535	1000	☆
Group PC: Multi-Multi-Reference and Simple PLC Function				
PC.00	Multi-Reference 0	-100.0% ~ 100.0%	0.0%	☆
PC.01	Multi-Reference 1	-100.0% ~ 100.0%	0.0%	☆
PC.02	Multi-Reference 2	-100.0% ~ 100.0%	0.0%	☆
PC.03	Multi-Reference 3	-100.0% ~ 100.0%	0.0%	☆
PC.04	Multi-Reference 4	-100.0% ~ 100.0%	0.0%	☆
PC.05	Multi-Reference 5	-100.0% ~ 100.0%	0.0%	☆
PC.06	Multi-Reference 6	-100.0% ~ 100.0%	0.0%	☆
PC.07	Multi-Reference 7	-100.0% ~ 100.0%	0.0%	☆

PC.08	Multi-Reference 8	-100.0% ~ 100.0%	0.0%	☆
PC.09	Multi-Reference 9	-100.0% ~ 100.0%	0.0%	☆
PC.10	Multi-Reference 10	-100.0% ~ 100.0%	0.0%	☆
PC.11	Multi-Reference 11	-100.0% ~ 100.0%	0.0%	☆
PC.12	Multi-Reference 12	-100.0% ~ 100.0%	0.0%	☆
PC.13	Multi-Reference 13	-100.0% ~ 100.0%	0.0%	☆
PC.14	Multi-Reference 14	-100.0% ~ 100.0%	0.0%	☆
PC.15	Multi-Reference 15	-100.0% ~ 100.0%	0.0%	☆

Group PD: Communication Parameters

Pd.00	Baud rate	Unit' s digit: MODBUS 0: 300BPS 1: 600BPS 2: 1200BPS 3: 2400BPS 4: 4800BPS 5: 9600BPS 6: 19200BPS 7: 38400BPS 8: 57600BPS 9: 115200BPS Ten' s digit: reserved Hundred' s digit: reserved Thousand' s: CAN BUS Baud rate 0: 20 1: 50 2: 100 3: 125 4: 250 5: 500	6005	☆
Pd.01	Data format	0: No check, <8-N-2> 1: Even parity check, <8-E-1> 2: Odd Parity check, <8-O-1> 3: 8-N-1	0	☆
Pd.02	Local address	1~247, 0: Broadcast address	1	☆
Pd.03	Response delay	0ms ~ 20ms	2	☆
Pd.04	Communication timeout	0.0 (invalid) , 0.1s~60.0s	0.0	☆
Pd.05	Data transfer format selection	MODBUS	01	☆
Pd.06	Communication reading current resolution	0: 0.01A 1: 0.1A	0	☆

Group PP: User-Defined Function Codes

PP.00	User password	0 ~ 65535	0	☆
PP.01	Parameter Initialization	0: No operation 01: Restore factory settings except motor parameters 02: Clear records	0	★

Group L3 Pulse synchronous

L3.00	Pulse synchronous mode	0: Speed synchronization 1: Position synchronization	0	★
L3.01	Pulse mode selection	0: Pulse + direction 1: 2 Orthogonal pulses	1	★
L3.02	Orthogonal pulse AB phase sequence	0: FWD 1: REV	0	★
L3.03	Acceleration time (position synchronization)	0.0 ~ 6500.0s	0.0s	☆
L3.04	Deceleration time (position synchronization)	0.0 ~ 6500.0s	0.0s	☆
L3.05	Feedforward gain (position synchronization)	0.00 ~ 2.00	1.00	★
L3.06	Proportional gain (position synchronization)	0.00 ~ 100.00	1.50	☆

L3.07	Electric gear ratio molecule	1 ~ 30000	1	☆
L3.08	Electric gear ratio denominator	1 ~ 30000	1	☆
L3.09	Pulse frequency filter time	0.00 ~ 10.00s	0	☆
L3.10	Pulse frequency sampling coefficient	0 ~ 100	0	☆
L3.11	Proportional gain switchover selection(position synchronization)	0: No switch 1:Switch according to deviation	1	☆
L3.12	Proportional gain 2(position synchronization)	0.00 ~ 100.00	15.00	☆
L3.13	Proportional gain switchover position deviation level 1(position synchronization)	0 ~ 30000	5	☆
L3.14	Proportional gain switchover position deviation level 2(position synchronization)	0 ~ 30000	50	☆
L3.15	Acceleration compensation gain	0.00 ~ 10.00	0.00	☆
L3.16	Maximum pulse deviation	0 ~ 10000	500	☆
L3.18	Deviation limit	0 ~ 1000	0	☆
L3.19	Pulse synchronization minimum given frequency	0.0010 ~ 0.0500Hz	0.0100Hz	☆
L3.21	Detection value of Pulse deviation too large	0 ~ 2000	600	☆

L3.22	Detection time of Pulse deviation too large	0.00 ~ 10.00s	1.00s	☆
-------	---	---------------	-------	---

Group L4 Position control

L4.00	Position control effective	0: Disabled 1: Enabled	0	☆
L4.01	Position mode selection	0: Incremental 1: Absolute 2: Indexing	2	★
L4.02	Indexing position encoder selection	0: Motor encoder 1: Spindle encoder	0	★
L4.03	Spindle position purpose encoder wire	1 ~ 65535	1024	★
L4.04	Spindle drive ratio molecule (spindle side gear)	1 ~ 10000	1	★
L4.05	Spindle drive ratio denominator (motor side gear)	1 ~ 10000	1	★
L4.06	Indexing position zero point source selection	0: position encoder Z signal 1: X terminal (X5)	0	★

L4.07	Zero point search direction	0: FWD 1: REV 2: Current direction	2	★
L4.08	Zero point search frequency	0.01 ~Maximum frequency	10.00Hz	☆
L4.09	Position control initial frequency	0.0 ~Maximum frequency	20.00Hz	☆
L4.10	Acceleration time (position control)	0.01 ~ 655.35s	3.00s	☆
L4.11	Deceleration time (position control)	0.01 ~ 655.35s	3.00s	☆
L4.12	Propotional gain 1 (position control)	0.00 ~ 100.00	1.00	☆
L4.13	X terminal zero point filter coefficient	0 ~ 200	10	☆
L4.14	Position complete deviation range	0 ~ 1000	10	☆
L4.15	Position complete deviation limit	0 ~ 1000	2	☆
L4.16	Propotional gain swithover selection	0: do not switch 1: switch according to deviation	1	☆
L4.17	Propotional gain 2 swithover selection	0.00 ~ 100.00	10.00	☆
L4.18	Propotional gain swithover pulse deviation 1	0 ~ 30000	5	☆
L4.19	Propotional gain swithover pulse deviation 2	0 ~ 30000	50	☆
L4.20	Indexing position command	0 ~ 65535	0	☆
L4.21	Indexing position command source selection	0: L4.20 1: Multi-position command (L4.22~L4.37)	0	☆

L4.22	Position control location command 1 low	0 ~ 65535	0	☆
-------	---	-----------	---	---

	position			
L4.23	Position control location command 1 high position	0 ~ 65535	0	☆
L4.24	Position control location command 2 low position	0 ~ 65535	0	☆
L4.25	Position control location command 2 high position	0 ~ 65535	0	☆
L4.26	Position control location command 3 low position	0 ~ 65535	0	☆
L4.27	Position control location command 3 high position	0 ~ 65535	0	☆
L4.28	Position control location command 4 low position	0 ~ 65535	0	☆
L4.29	Position control location command 4 high position	0 ~ 65535	0	☆
L4.30	Position control location command 5 low position	0 ~ 65535	0	☆
L4.31	Position control location command 5 high position	0 ~ 65535	0	☆
L4.32	Position control location command 6 low position	0 ~ 65535	0	☆
L4.33	Position control location command 6 high position	0 ~ 65535	0	☆
L4.34	Position control location command 7 low position	0 ~ 65535	0	☆
L4.35	Position control location command 7 high position	0 ~ 65535	0	☆
L4.36	Position control location command 8 low position	0 ~ 65535	0	☆
L4.37	Position control location command 8 high level	0 ~ 65535	0	☆

L4.38	Position control command direction 1	0: FWD 1: REV Unit' s digit: position control command 1 direction Ten' s digit: position control command 2 direction Hundred' s digit: position control command 3 direction Thousand' s digit: position control command 4 direction Ten thousand' s digit: position control command 5 direction	00000	☆
L4.39	Position control command direction 2	0: FWD 1: REV Unit' s digit: position control command 6 direction Ten' s digit: position control command 7 direction Hundred' s digit: position control command 8 direction	000	☆
L4.40	Position control maximum frequency	0.00Hz ~ P0.10	50.00Hz	☆
L4.41	Position control location command 9 low position	0 ~ 65535	0	☆
L4.42	Position control location command 9 high position	0 ~ 65535	0	☆
L4.43	Position control location command 10 low position	0 ~ 65535	0	☆
L4.44	Position control location command 10 high position	0 ~ 65535	0	☆

L4.45	Position control location command 11 low position	0 ~ 65535	0	☆
L4.46	Position control location command 11 high position	0 ~ 65535	0	☆
L4.47	Position control location command 12 low position	0 ~ 65535	0	☆
L4.48	Position control location command 12 high position	0 ~ 65535	0	☆
L4.49	Position control location command 13 low position	0 ~ 65535	0	☆
L4.50	Position control location command 13 high position	0 ~ 65535	0	☆

L4.51	Position control location command 14 low position	0 ~ 65535	0	☆
L4.52	Position control location command 14 high position	0 ~ 65535	0	☆
L4.53	Position control location command 15 low position	0 ~ 65535	0	☆
L4.54	Position control location command 15 high position	0 ~ 65535	0	☆
L4.55	Position control location command 16 low position	0 ~ 65535	0	☆
L4.56	Position control location command 16 high position	0 ~ 65535	0	☆

L4.57	Position control command direction 3	0: FWD 1: REV Unit' s digit: position control command 9 direction Ten' s digit: position control command 10 direction Hundred' s digit: position control command 11 direction Thousand' s digit: position control command 12 direction Ten thousand' s digit: position control command 13 direction	00000	☆
L4.58	Position control command direction 4	0: FWD 1: REV Unit' s digit: position control command 14 direction Ten' s digit: position control command 15 direction Hundred' s digit: position control command 16 direction	000	☆
L4.59	Position control location command 17 low position	0 ~ 65535	0	☆
L4.60	Position control location command 17 high position	0 ~ 65535	0	☆
L4.61	Position control location command 18 low position	0 ~ 65535	0	☆
L4.62	Position control location command 18 high position	0 ~ 65535	0	☆
L4.63	Position control location command 19 low position	0 ~ 65535	0	☆
L4.64	Position control location command 19 high position	0 ~ 65535	0	☆

L4.65	Position control location command 20 low position	0 ~ 65535	0	☆
L4.66	Position control location command 20 high position	0 ~ 65535	0	☆
L4.67	Position control location command 21 low position	0 ~ 65535	0	☆
L4.68	Position control location command 21 high position	0 ~ 65535	0	☆
L4.69	Position control location command 22 low position	0 ~ 65535	0	☆
L4.70	Position control location command 22 high position	0 ~ 65535	0	☆
L4.71	Position control location command 23 low position	0 ~ 65535	0	☆
L4.72	Position control location command 23 high position	0 ~ 65535	0	☆
L4.73	Position control location command 24 low position	0 ~ 65535	0	☆
L4.74	Position control location command 24 high position	0 ~ 65535	0	☆
L4.75	Position control command direction 5	0: FWD 1: REV Unit' s digit: position control command 17 direction Ten' s digit: position control command 18 direction Hundred' s digit: position control command 19 direction Thousand' s digit: position control command 20 direction Ten thousand' s digit: position control command 21 direction	00000	☆

L4.76	Position control command direction 6	0: FWD 1: REV Unit' s digit: position control command 22 direction Ten' s digit: position control command 23 direction Hundred' s digit: position control command 24 direction	000	☆
L4.77	Position control location command 25 low position	0 ~ 65535	0	☆
L4.78	Position control location command 25 high position	0 ~ 65535	0	☆
L4.79	Position control location command 26 low position	0 ~ 65535	0	☆
L4.80	Position control location command 26 high position	0 ~ 65535	0	☆
L4.81	Position control location command 27 low position	0 ~ 65535	0	☆
L4.82	Position control location command 27 high position	0 ~ 65535	0	☆
L4.83	Position control location command 28 low position	0 ~ 65535	0	☆
L4.84	Position control location command 28 high position	0 ~ 65535	0	☆
L4.85	Position control location command 29 low position	0 ~ 65535	0	☆
L4.86	Position control location command 29 high position	0 ~ 65535	0	☆
L4.87	Position control location command 30 low position	0 ~ 65535	0	☆
L4.88	Position control location command 30 high position	0 ~ 65535	0	☆

L4.89	Position control location command 31 low position	0 ~ 65535	0	☆
L4.90	Position control location command 31 high position	0 ~ 65535	0	☆
L4.91	Position control location command 32 low position	0 ~ 65535	0	☆
L4.92	Position control location command 32 high position	0 ~ 65535	0	☆
L4.93	Position control command direction 7	0: FWD 1: REV Unit' s digit: position control command 25 direction Ten' s digit: position control command 26 direction Hundred' s digit: position control command 27 direction Thousand' s digit: position control command 28 direction Ten thousand' s digit: position control command 29 direction	00000	☆
L4.94	Position control command direction 8	0: FWD 1: REV Unit' s digit: position control command 30 direction Ten' s digit: position control command 31 direction Hundred' s digit: position control command 32 direction	000	☆
L4.95	Detection of zero point judgment error	0 ~ 1000	10	☆

L4.96	Position proximity judgment pulse	0 ~ 10000	100	
-------	-----------------------------------	-----------	-----	--

Group L6 F1 Curve setting				
L6.00	F1 curve 4 minimum input	-10.00V ~ L6.02	0.00V	☆
L6.01	Corresponding setting of F1 curve 4 minimum input	-100.0% ~ +100.0%	0.0%	☆
L6.02	F1 curve 4 inflexion 1 input	L6.00 ~ L6.04	3.00V	☆
L6.03	Correspondingv setting to F1 curve 4 inflexion 1 input	-100.0% ~ +100.0%	30.0%	☆
L6.04	F1 curve 4 inflexion 2 input	L6.02 ~ L6.06	6.00V	☆
L6.05	Correspondingv setting to F1 curve 4 inflexion 2 input	-100.0% ~ +100.0%	60.0%	☆
L6.06	F1 curve 4 maximum input	L6.06 ~ +10.00V	10.00V	☆
L6.07	Corresponding setting of F1 curve 4 maximum input	-100.0% ~ +100.0%	100.0%	☆
L6.08	F1 curve 5 minimum input	-10.00V ~ L6.10	-10.00V	☆
L6.09	Corresponding setting of F1 curve 5 minimum input	-100.0% ~ +100.0%	-100.0%	☆
L6.10	F1 curve 5 inflexion 1 input	L6.08 ~ L6.12	-3.00V	☆
L6.11	Corresponding setting of F1 curve 5 inflexion 1 input	-100.0% ~ +100.0%	-30.0%	☆
L6.12	F1 curve 5 inflexion 2 input	L6.10 ~ L6.14	3.00V	☆

L6.13	Corresponding setting of FI curve 5 inflexion 2 input	-100.0% ~ +100.0%	30.0%	☆
L6.14	FI curve 5 maximum input	L6.12 ~ +10.00V	10.00V	☆
L6.15	Corresponding setting of FI curve 5 maximum input	-100.0% ~ +100.0%	100.0%	☆
L6.24	Jump point of FIV input	-100.0% ~ 100.0%	0.0%	☆
L6.25	Jump amplitude of FIV input	0.0% ~ 100.0%	0.5%	☆
L6.26	Jump point of FIC input	-100.0% ~ 100.0%	0.0%	☆
L6.27	Jump amplitude of FIC input	0.0% ~ 100.0%	0.5%	☆
L6.28	Reserved		0.0%	☆
L6.29	Reserved		0.0%	☆

If PP-00 is set to a non-zero number, parameter protection is enabled. You must enter the correct user password to enter the menu. To cancel the password protection function, enter with password and set PP-00 to 0.

Parameters menu the user customizes are not protected by password.

Group P ,L is the basic function parameters , Group D is to tunned monitor the function parameters.The symbols in the function code table are described as follows:

"☆": The parameter can be modified when the AC drive is in either stop or running state.

"★": The parameter cannot be modified when the AC drive is in the running state.

"●": The parameter is the actually measured value and cannot be modified.

"*": The parameter is factory parameter and can be set only by the manufacturer.

3. Monitoring Parameters list

Code	Name	Unit
Group D0: Monitoring Parameters		
D0.00	Running frequency (Hz)	0.01Hz

D0.01	Set frequency (Hz)	0.01Hz
D0.02	Bus voltage (V)	0.1V
D0.03	Output voltage (V)	1V
D0.04	Output current (A)	0.01A
D0.05	Output power (kW)	0.1kW
D0.06	Output torque (%)	0.1%
D0.07	X input state	1
D0.08	YO output state	1
D0.09	FIV voltage (V)	0.01V
D0.10	FIC voltage (V)	0.01V/0.01mA
D0.11	Reserved voltage (V)	0.01V
D0.12	Count value	1
D0.13	Length value	1
D0.14	Load speed show	1
D0.15	PID setting	1
D0.16	PID feedback	1
D0.17	PLCstage	1
D0.18	Input pulse frequency(kHz)	0.01kHz
D0.19	Feedback speed (Hz)	0.01Hz
D0.20	Remaining running time	0.1Min
D0.21	FIV voltage before correction	0.001V
D0.22	FIC voltage/current before correction	0.001V/0.01mA
D0.23	Reserved	保留

D0.24	Linear speed	1m/Min
-------	--------------	--------

D0.25	On the current time	1Min
D0.26	The current running time	0.1Min
D0.27	Pulse input frequency	1Hz
D0.28	Communication setting value	0.01%
D0.29	Encoder feedback speed	0.01Hz
D0.30	Main frequency X display	0.01Hz
D0.31	Auxiliary frequency Y show	0.01Hz
D0.32	View any memory address values	1
D0.34	Motor temperature value	1°C
D0.35	Target torque(%)	0.1%
D0.36	Rotation position	1
D0.37	Power factor angle	0.1°
D0.38	ABZ position	1
D0.39	Target voltage upon V/F separation	1V
D0.40	Output voltage upon V/F separation	1V
D0.41	X input status visual display	1
D0.42	Y0 input status visual display	1
D0.43	X function status visual display 1 (function 01-function 40)	1
D0.44	X function status visual display 2 (function 41-function 80)	1

Group D1 Position control

D1.00	Position control follow error	1pulse
D1.01	Pulse position follow error	1pulse
D1.02	Relative to zero point position	1pulse
D1.03	External pulse given motor running frequency (after drive ratio calculate)	0.01Hz
D1.04	External pulse given frequency	0.01kHz
D1.05	Position complete signal	1
D1.06	Search for zero point	1
D1.07	Motor actual rotate speed	1rpm/min
D1.08	Relative to zero position high position	1pulse
D1.09	Relative to zero position low position	1pulse
D1.10	Pulse given number high position	1pulse
D1.11	Pulse given number low position	1pulse
D1.12	External pulse given motor running frequency (before drive ratio calculate)	0.01Hz
D1.13	Relative to zero point position direction	1
D1.14	Position approach	1
D1.15	Between Twice zero point signal pulse	1pulse

Chapter 5 Fault checking and ruled out

5.1 Fault alarm and countermeasures

T8000D with a total of 24 warning information and the protection function, once the failure, protection function, inverter to stop output, inverter fault relay contact action, and in the inverter fault code shown on the display panel. the user can check himself according to the tips before seeking service, analyze the cause of the

problem, find out the solution. If it is belong to the dotted line frame stated reason, please seek service ,with your purchased inverter agents or direct contact with our company.

warning information OUOC is overcurrent or overvoltage signals for hardware, in most cases the hardware overvoltage fault cause OUOC alarm.

Fault Name	Display	Possible causes	Solutions
Inverter unit protection	OC	1: The output circuit is grounded or short circuited. 2: The connecting cable of the motor is too long. 3: The module overheats. 4: The internal connections become loose. 5: The main control board is faulty. 6: The drive board is faulty. 7: The inverter module is faulty	1: Eliminate external faults. 2: Install a reactor or an output filter. 3: Check the air filter and the cooling fan. 4: Connect all cables Properly. 5: Looking for technical support 6: Looking for technical support 7: Looking for technical support

Over-current during acceleration	OC1	<ul style="list-style-type: none"> 1: The output circuit is grounded or short circuited. 2: Motor auto-tuning is not Performed. 3: The acceleration time is too Short. 4: Manual torque boost or V/F curve is not appropriate. 5: The voltage is too low. 6: The startup operation is performed on the rotating motor. 7: A sudden load is added during Acceleration. 8: The AC drive model is of too small power class. 	<ul style="list-style-type: none"> 1: Eliminate external faults. 2: Perform the motor auto-tuning . 3: Increase the acceleration time. 4: Adjust the manual torque boost or V/F curve. 5: Adjust the voltage to normal range. 6: Select rotational speed tracking restart or start the motor after it stops. 7: Remove the added load. 8: Select an AC drive of higher power class.
Over-current during acceleration	OC2	<ul style="list-style-type: none"> 1: The output circuit is grounded or short circuited. 2: Motor auto-tuning is not performed. 3: The deceleration time is too Short. 4: The voltage is too low. 5: A sudden load is added during Deceleration. 6: The braking unit and braking resistor are not installed. 	<ul style="list-style-type: none"> 1: Eliminate external faults. 2: Perform the motor auto-tuning. 3: Increase the deceleration time. 4: Adjust the voltage to normal range. 5: Remove the added load. 6: Install the braking unit and braking resistor.

Over-current at constant speed	OC3	<ol style="list-style-type: none"> 1: The output circuit is grounded or short circuited. 2: Motor auto-tuning is not performed. 3: The voltage is too low. 4: A sudden load is added during operation. 5: The AC drive model is of too small power class. 	<ol style="list-style-type: none"> 1: Eliminate external faults. 2: Perform the motor auto-tuning. 3: Adjust the voltage to normal range. 4: Remove the added load. 5: Select an AC drive of higher power class.
Over-voltage during acceleration	OU1	<ol style="list-style-type: none"> 1: The input voltage is too high. 2: An external force drives the motor during acceleration. 3: The acceleration time is too Short. 4: The braking unit and braking resistor are not installed. 	<ol style="list-style-type: none"> 1: Adjust the voltage to normal range. 2: Cancel the external force or install a braking resistor. 3: Increase the acceleration time. 4: Install the braking unit and braking resistor.
Over-voltage during deceleration	OU2	<ol style="list-style-type: none"> 1: The input voltage is too high. 2: An external force drives the motor during deceleration. 3: The deceleration time is too Short. 4: The braking unit and braking resistor are not installed. 	<ol style="list-style-type: none"> 1: Adjust the voltage to normal range. 2: Cancel the external force or install the braking resistor. 4: Install the braking unit and braking resistor.
Over-voltage at constant speed	OU3	<ol style="list-style-type: none"> 1: The input voltage is too high. 2: An external force drives the motor during deceleration. 	<ol style="list-style-type: none"> 1: Adjust the voltage to normal range. 2: Cancel the external force or install the

			braking resistor.
Control power supply fault	POFF	1、输入电压不在规范规定的范围内 The input voltage is not within the allowable range.	1、将电压调至规范要求的范围内 Adjust the input voltage to the allowable range.
欠压 Lack of voltage	Hn	1、瞬时停电 2、驱动器输入端电压不在规范要求的范围 3、母线电压不正常 4、整流桥及缓冲电阻不正常 5、驱动板异常 6、控制板异常 1: Instantaneous power failure occurs on the input power supply. 2: The AC drive's input voltage is not within the allowable range. 3: The bus voltage is abnormal. 4: The rectifier bridge and buffer resistor are abnormal. 5: The drive board is abnormal. 6: The main control board is abnormal.	1、复位故障 2、调整电压到正常范围 3、寻求技术支持 4、寻求技术支持 5、寻求技术支持 6、寻求技术支持 1: Reset the fault. 2: Adjust the voltage to normal range. 3,4,5,6: Looking for technical support
驱动器过载 drive overload	OL2	1、负载是否过大或发生电机堵转 2、驱动器选型偏小 1: The load is too heavy or motor-stalled occurs on the motor. 2: The AC drive model is of too small power class.	1、减小负载并检查电机及机械情况 2、选用功率等级更大的驱动器 1: Reduce the load and check the motor and mechanical condition. 2: Select an AC drive of higher power class.
电机过载 Motor overload	OL1	1、电机保护参数 P9.01 设定是否合适 2、负载是否过大或发生电机堵转 3、驱动器选型偏小 1: P9.01 is set improperly.	1、正确设定此参数 2、减小负载并检查电机及机械情况 3、选用功率等级更大的驱动器 1: Set P9.01 correctly. 2: Reduce the load and

		<p>2: The load is too heavy or motor-stalled occurs on the motor.</p> <p>3: The AC drive model is of too small power class.</p>	<p>check the motor and the mechanical condition.</p> <p>3: Select an AC drive of higher power class.</p>
输入缺相	LI	<p>1. 3 phase input power supply is faulty</p> <p>2. Drive board is faulty</p> <p>3. Lightning protection board is faulty</p> <p>4. Main control board is faulty</p>	<p>1. Check and Eliminate external circuit faults.</p> <p>2,3,4 looking for technical support</p>
Power output phase loss	Lo	<p>1: The cable connecting the AC drive and the motor is faulty.</p> <p>2: The AC drive's three-phase output is unbalanced when the motor is running.</p> <p>3: The drive board is faulty.</p> <p>4: The module is faulty.</p>	<p>1: Eliminate external faults.</p> <p>2: Check whether the motor three-phase winding is normal.</p> <p>3: Looking for technical support .</p>
Module overheat	OH	<p>1: The ambient temperature is too high..</p> <p>2: The air filter is blocked.</p> <p>3: The fan is damaged.</p> <p>4:The thermally sensitive resistor of the module is damaged.</p> <p>5:The inverter module is damaged.</p>	<p>1: Lower the ambient temperature.</p> <p>2: Clean the air filter.</p> <p>3: Replace the damaged fan.</p> <p>4: Replace the damaged thermally sensitive resistor.</p> <p>5:Replace the inverter module.</p>
External equipment fault	EF	<p>1: External fault signal is input via X.</p> <p>2: External fault signal is input via virtual I/O.</p>	<p>Reset the operation.</p>
Communication fault	CE	<p>1: The host computer is in abnormal state.</p> <p>2: The communication cable is faulty.</p> <p>3: P028 is set improperly.</p> <p>4: The communication parameters in group PD are set improperly.</p>	<p>1: Check the cabling of host computer.</p> <p>2: Check the communication cabling.</p> <p>3: Set P028 correctly.</p> <p>4: Set the communication parameters properly.</p>

Contactor fault	RAy	1: The drive board and power supply are faulty. 2: The contactor is faulty.	1: Replace the faulty drive board or power supply board. 2: Replace the faulty Contactor.
Contactor fault	IE	1: The drive board and power supply are faulty. 2: The contactor is faulty.	1: Replace the faulty drive board or power supply board. 2: Replace the faulty Contactor.
Motor auto-tuning fault	TE	1: The motor parameters are not set according to the nameplate. 2: The motor auto-tuning times out.	1: Set the motor parameters according to the nameplate properly. 2: Check the cable connecting the AC drive and the motor.
PG card fault	PG	1: Encoder type is incorrect 2: The cable connection of the encoder is incorrect 3: The encoder is damaged 4: The PG card is faulty	1: Set the encoder type correctly based on the actual situation 2: Check the connect wire 3: Change Encoder 4: Change the PG card
EEPROM read-write fault	EEP	The EEPROM chip is damaged.	Replace the main control board.
AC drive hardware fault	OUOC	1: Over-voltage exists. 2: Over-current exists.	1: Handle based on Over-voltage. 2: Handle based on Over-current.
Short circuit to ground fault	GND	The motor is short circuited to the ground.	Replace the cable or motor.
Accumulative running	END1	The accumulative running time reaches the setting value.	Clear the record through the parameter initialization function.

time reached			
Accumulative power-on time reached	END2	The accumulative power-on time reaches the setting value.	Clear the record through the parameter initialization function.
Load becoming 0	LOAD	The AC drive running current is lower than P9.64.	Check that the load is disconnected or the setting of P9.64 and P9.65 is correct.
PID feedback lost during running fault	PIDE	The PID feedback is lower than the setting of PA.26.	Check the PID feedback signal or set PA.26 to a proper value.
Pulse-by-pulse current limit fault	CBC	1: The load is too heavy or locked-rotor occurs on the motor. 2: The AC drive model is of too small power class.	1: Reduce the load and check the motor and mechanical condition. 2: Select an AC drive of higher power class.
Too large speed deviation fault	ESP	P9.69、P9.70 设置不合理 1: The encoder parameters are set incorrectly. 2: The motor auto-tuning is not Performed. 3:Parameters of too large speed deviation P9.69 and P9.70 are set incorrectly.	1: Set the encoder parameters properly. 2:Perform the motor auto-tuning. 3: Set P9.69 and P9.70 correctly based on the actual situation.
Motor over-speed fault	oSP	P9.67、P9.68 设置不合理 1: The encoder parameters are set Incorrectly. 2: The motor auto-tuning is not Performed. 3:Motor over-speed detection parameters P9.69 and P9.70 are set incorrectly.	1: Set the encoder parameters properly. 2: Perform the motor auto-tuning. 3:Set motor over-speed detection parameters correctly based on the actual situation.
Initial	INI	Motor parameter is deviated too	Confirm whether the

position fault		large to actual	motor parameter is correct, especially to the rated current
----------------	--	-----------------	---

5.2 Common Faults and Solutions

You may come across the following faults during the use of the AC drive. Refer to the following table for simple fault analysis.

5-1 Troubleshooting to common faults of the AC drive

NO	Fault	Possible Cause	Solution
1	There is no display when the power is on	1: There is no power supply to the AC drive or the power input to the AC drive is too low. 2: The power supply of the switch on the drive board of the AC drive is Faulty. 3: The rectifier bridge is damaged. 4: The control board or the operation panel is faulty. 5: The cable connecting the control board and the drive board and the operation panel breaks.	1: Check the power supply. 2: Check the bus voltage. 3: Looking for technical support
2	“8000” is displayed when the power is on	1: The cable between the drive board and the control board is in poor contact. 2: Related components on the control board are damaged. 3: The motor or the motor cable is short circuited to the ground. 4: The HALL device is faulty. 5: The power input to the AC drive is too low.	Looking for technical support
3	“GND” is displayed when the power is on	1: The motor or the motor output cable is short-circuited to the ground. 2: The AC drive is damaged.	1: Measure the insulation of the motor and the output cable with a megger. 2: Looking for technical support

4	The AC drive display is normal when the power is on. But “2000” is displayed after running and stops immediately.	1: The cooling fan is damaged or locked-rotor occurs. 2: The external control terminal cable is short circuited.	1: Replace the damaged fan. 2: Eliminate external faults.
5	OH (module overheat) fault is reported frequently.	1: The setting of carrier frequency is too high. 2: The cooling fan is damaged, or the air filter is blocked. 3: Components inside the AC drive are damaged (thermal coupler or others).	1: Reduce the carrier frequency (P0.15). 2: Replace the fan and clean the air filter. 3: Looking for technical support
6	The motor does not rotate after the AC drive runs.	1: Check the motor and the motor Cables. 2: The AC drive parameters are set improperly (motor parameters). 3: The cable between the drive board and the control board is in poor contact. 4: The drive board is faulty	1: Ensure the cable between the AC drive and the motor is normal. 2: Replace the motor or clear mechanical faults. 3: Check and reset motor parameters.
7	The X terminals are disabled.	1: The parameters are set incorrectly. 2: The external signal is incorrect 3: The jumper bar across OP and +24 V becomes loose. 4: The control board is faulty	1: Check and reset the parameters in group P5. 2: Re-connect the external signal cables. 3: Re-confirm the jumper bar across OP and +24 V. 4: Looking for technical support
8	While in close loop vector	Encoder fault, encoder wiring are fault or disconnect, PG card fault, drive board fault.	Change encoder and wire again correct, change PG card, looking for technical

	control mode, motor can not boost		support.
9	The AC drive reports Over-current and over-voltage frequently.	1: The motor parameters are set improperly. 2: The acceleration/deceleration time is improper. 3: The load fluctuates.	1: Reset motor parameters or re-perform the motor auto-tuning . 2: Set proper acceleration/ deceleration time. 3: Looking for technical support
10	RAY is reported when the power is or the AC drive is running.	The soft startup contactor is not picked up.	1: Check whether the contactor cable is loose. 2: Check whether the contactor is faulty. 3: Check whether 24 V power supply of the contactor is faulty. 4: Looking for technical support

6.3.

Synchronous auto tuning fault (TE) (P1.37=11

- (1) P2.10 torque upper limit setting value is too small
- (2) Encoder wire number is wrong or converted polar logarithm is wrong, it is rated rotate speed or rated frequency setting is wrong.
- (3) Encoder PG card didn't connect correct or damaged.
- (4) Encoder type setting fault, for example rotate set as ABZ or UVW.
- (5) If all parameter set above are no problem, encoder is normal, and auto tuning can't work, set the encoder sequence P1.30 to opposite, and auto tuning again; if still can't work, the motor load may too heavy, suggest bigger drive and try.

6.4 Synchronous motor PG card fault

This fault are with some reasons, need to view D0.45 additional info. There are 1-7, and 11, 12, which 9 kind situation of D0.45, show as below:

D0.45=1, it indicates that the encoder is not connected or encoder and PG care are damaged while autotuning with no load

D0.45=2, it indicates that UVW signal fault, may not connect or damaged, only display with UVW encoder.

D0.45=3, it indicates that the Z signal of ABZ or UVW encoder are disturbed or not received while auto tuning with no load.

D0.45=4. It indicates that the signal direction of UVW are fault while auto tuning with load. It may not connected or damaged.(Only warning for UVW)

D0.45=5, it indicates Z signal are not received while auto tuning with load, the encoder Z signal may not connected or damaged. (Rotating, ABZ and UVW may warning)

D0.45=6, only when running it will warning this fault, it indicates that the magnetic field position angle are deviated, only ABZ and UVW will warning this fault. The reason is that Z signal or ABZ signal are disturbed, you can change the zero position angle(P1.31) by hand.

D0.45=7, Encoder wire number setting method are wrong if for ABZ or UVW; The feedback wiring or PG card are not connected if for rotating. If the pole setting are wrong, all type encoder will display this fault, it need to check whether the calculate pole of the rated frequency and rated rotating are correct or not.

D0.45=11, it indicates that the three signal cable of UVW are connect wrong or not connected, if only display for UVW encoder. If it is confirm this fault are warning in mistake, set P9.71=1 to shield this fault.

D0.45=12, it indicates that Encoder or PG card are damaged or UVW signal cable connected wrong. If it is confirm this fault are warning in mistake, set P9.71=1 to shield this fault.

Chapter 6 Maintenance



WARNING

- Maintenance must be performed according to designated maintenance methods.
- Maintenance, inspection and replacement of parts must be performed only by certified person.
- After turning off the main circuit power supply, wait for 10 minutes before maintenance or inspection.
- DO NOT directly touch components or devices of PCB board. Otherwise inverter can be damaged by electrostatic.
- After maintenance, all screws must be tightened.

6.1 Inspection

In order to prevent the fault of inverter to make it operate smoothly in high-performance for a long time, user must inspect the inverter periodically (within half

year). The following table indicates the inspection content.

Items to be checked	contents
Temperature/humidity	ambient temperature shall be lower than 40°C Humidity shall meet the requirement of 20~90% and has no Gel
Smoke and dust	No dust accumulation,no traces of water leakage and no condensate.
Inverter	Check the inverter to ensure it has no abnormal heat. abnormal vibration
fan	Ensure the fan operation is normal,no debris stuck,etc.
power input	power input voltage and frequency are at the permissible range
Motor	To check the motor whether the motor has abnormal vibration ; abnormal heat; abnormal noise and phase loss,etc

6.2 Periodic Maintenance

Customers should check the drive in a regular time to make it operate smoothly in high-performance for a long time.the checking contents are as follows:

Items to be checked	checking contents	Solutions
the screws of control terminals	whether the screws of control terminals are loose	tighten them
PCB	Duct and dirt	Clean the dust on PCBs and air ducts with a vacuum cleaner
Fan	abnormal noise, abnormal vibration, whether it has used up 20,000 hours	Clear debris and replace the fan
Electrolytic capacitor	Whether the color is changed and the smell is abnormal	Change the electrolytic capacitor
Heatsink	Duct and dirt	Clean the dust and air ducts with a vacuum cleaner
Power Components	Duct and dirt	Clean the dust and air ducts with a vacuum cleaner

6.3 Replacement of wearing parts

Fans and electrolytic capacitors are wearing part, please make periodic replacement to ensure long term, safety and failure-free operation. The replacement periods are as follows:

- ◆ Fan: Must be replaced when using up to 20,000 hours;
- ◆ Electrolytic Capacitor: Must be replaced when using up to 30,000~40,000

hours.

6.4 Inverter Warranty

The company provides 12 months of warranty for T8000D Inverter since it go out from the factory

Chapter 7 Peripheral Devices Selection

devices name	Descriptions
Circuit breaker and leakage breaker.	Protect inverter wiring, convenient to the installation and maintenance.
Electromagnetic contactor	Inverter is convenient to the power supply's power-on and power-off ,ensure the safety
Surge absorber	
Isolation Transformers	Isolation to the Inverter's input and output, Reduce interference
DC Reactor	Protect the Inverter and suppress higher harmonics.
AC Reactor	Protect the Inverter and suppress higher harmonics. Prevent the impact of surge voltage
Brake resistor and brake unit	Absorb the renewable Energy
Noise filter	To reduce the electromagnetic disturbance which is generated by inverter.
Ferrite ring	To reduce the electromagnetic disturbance which is generated by inverter.

7.1 Applied DC reactor Specification

Drive model	(KW) Power	DC reactor parameter		Remark
		(A) Rated current	(mH) Inductance	
T8400D-3R7G/5R5P	3.7/5.5	12	6.3	Optional
T8400D-5R5G/7R5P	5.5/7.5	23	3.6	
T8400D-7R5G/11P	7.5/11	23	3.6	

T8400D-11G/15P	11/15	33	2	
T8400D-15G/18R5P	15/18.5	33	2	
T8400D-18R5G/22P	18.5/22	40	1.3	
T8400D-22G/30P	22/30	50	1.08	

7.2 AC input reactor

Drive model	(KW) Power	AC reactor parameter		Remark
		Rated current (A)	(mH)	
T8400D-3R7G/5R5P	3.7/5.5	10	1.5	Optional
T8400D-5R5G/7R5P	5.5/7.5	15	1	
T8400D-7R5G/11P	7.5/11	20	0.75	
T8400D-11G/15P	11/15	30	0.6	
T8400D-15G/18R5P	15/18.5	40	0.42	
T8400D-18R5G/22P	18.5/22	50	0.35	
T8400D-22G/30P	22/30	60	0.28	

7.3 AC output reactor

Drive model	Power (KW)	AC reactor parameter		Remark
		Rated current (A)	Inductance (mH)	
T8400D-3R7G/5R5P	3.7/5.5	10	0.6	Optional
T8400D-5R5G/7R5P	5.5/7.5	15	0.25	
T8400D-7R5G/11P	7.5/11	20	0.13	
T8400D-11G/15P	11/15	30	0.087	
T8400D-15G/18R5P	15/18.5	40	0.066	
T8400D-18R5G/22P	18.5/22	50	0.052	
T8400D-22G/30P	22/30	60	0.045	

7.4 Braking resistor

Drive model	brake resistor		Brake unit CDBR	Brake Torque (10%ED)	Motor (KW)
	Power W	Resistance Ω (\geq)			
T8400D-3R7G/5R5P	300W	130	Built-in	125	3.7/5.5
T8400D-5R5G/7R5P	400W	90		125	5.5/7.5
T8400D-7R5G/11P	500W	65		125	7.5/11
T8400D-11G/15P	800W	43		125	11/15
T8400D-15G/18R5P	1000W	32		125	15/18.5
T8400D-18R5G/22P	1300W	25		125	18.5/22
T8400D-22G/30P	1500W	22		125	22/30

Remark: The Braking resistor value is related to the DC currency when the inverter braking. For 380V power supply, the braking DC voltage is 800V-820V, and for 220V system, the DC voltage is 400V.

Moreover, the Braking resistor value is related to braking torque $M_{br}\%$, and to the different braking torque the Braking resistor values are different, and the calculation formula is as follow:

$$R = \frac{U_{dc}^2 \times \%}{P_{Motor} \times M_{br}\% \times \eta_{Transducer} \times \eta_{Motor}}$$

Among them,

U_{dc} ——Braking DC voltage;

P_{Motor} ——Motor power;

M_{br} ——Braking torsion;

η_{Motor} ——Motor efficiency;

$\eta_{Transducer}$ ——Transducer efficiency.

The braking power is related to braking torque and braking frequency. the foregoing illustration gives the braking torque as 125% and the frequency is 10%, and according to the different loading situations, the datas in the illustration are for reference.

