

H6000S

**Series Sensorless
Vector Control Inverter**

User's Manual

- Thank you very much for your buying H6000S series sensorless vector control inverter.
- Before use, please read this manual thoroughly to ensure proper usage. Keep this manual at an easily accessible place so that can refer anytime as necessary.

Safety Precautions

Please read this operation manual carefully before installation, operation, maintenance or inspection. In this manual, the safety precautions were sorted to “WARNING” or “CAUTION”.



WARNING

Indicates a potentially dangerous situation which, if can not avoid will result in death or serious injury.



CAUTION

Indicates a potentially dangerous situation which, if can not avoid will cause minor or moderate injury and damage the device. This Symbol is also used for warning any un-safety operation.

In some cases, even the contents of “CAUTION” still can cause serious accident. Please follow these important precautions in any situation.

In some cases, even the contents of “CAUTION” still can cause serious accident. Please follow these important precautions in any situation.

In some cases, even the contents of “CAUTION” still can cause serious accident. Please follow these important precautions in any situation.

★ NOTE indicate the necessary operation to ensure the device run properly.

Warning Marks are placed on the front cover of the inverter.

Please follow these indications when using the inverter.

WARNING
<ul style="list-style-type: none"> ● May cause injury or electric shock. ● Please follow the instructions in the manual before installation or operation. ● Disconnect all power line before opening front cover of unit. Wait at least 10 minutes until DC Bus capacitors discharge. ● Use proper grounding techniques. ● Never connect AC power to output UVW terminals.

Contents

Chapter 1 Introduction	1
1.1 Technology Features	1
1.2 Description of Name Plate.....	2
1.3 Selection Guide	3
1.4 Inverter outline dimension drawings.....	5
1.5. INSPECTION	7
1.6. INSTALLATION	7
1.7 Environmental Requirement.....	8
1.8 Installation Space	9
Chapter 2 Wiring	11
2.1 Connection of Peripheral Devices	11
2.2 Terminal Configuration	12
2.2.1 Main Circuit Terminals	12
2.2.2 Control Circuit Terminals	13
2.3 Wiring Diagram.....	14
2.4 Wiring Main Circuits	15
2.4.1 Wiring at input side of main circuit.....	15
2.4.2 Wiring at inverter side of main circuit	15
2.4.3 Wiring at motor side of main circuit	16
2.4.4 Wiring of regenerative unit	17
2.4.5 Wiring of Common DC bus.....	17

2.4.6 Ground Wiring (PE)	18
2.5 Installation Guideline to EMC Compliance	18
2.5.1 General knowledge of EMC	19
2.5.2 EMC features of inverter	19
2.5.3 EMC Installation Guideline	20
Chapter 3 Operation	24
3.1 Keypad Description	24
3.2 Function key description.....	24
3.3 Indicator light description.....	25
3.4 Operation Process.....	26
3.4.1 Parameter setting	26
3.4.2 Fault reset	27
3.4.3 Motor parameter autotuning	27
3.4.4 Password setting	28
3.5 Running State.....	28
3.5.1 Power-on initialization	28
3.5.2 Stand-by	28
3.5.3 Motor parameter autotuning	29
3.5.4 Operation.....	29
3.5.5 Fault	29
3.6 Quick Testing.....	29
Chapter 4 Detailed Function Description	31
4.1 F0 Group--Basic Function	31
4-2 F1 Group--Motor Parameters.....	40
4-3 F2 Group: Vector Control	41
4-4F3 Group: V/F Control.....	44
4-5 F4 Group: Input Terminals.....	47
4-6 F5 Group: Output Terminals	54

4-7 F6 Group: Start and Stop Control	58
4-8 F7 Group: Display Interface	63
4-10 F9 Group: PID Control	75
4-11 FA Group: Simple PLC and Multi-step Speed Control.....	79
4-12 Fb Group: Protection Function	85
4-13 FC Group: Serial Communication	89
Chapter 5 Trouble Shooting	92
5.1 Fault and Trouble shooting.....	92
5.2 Fault and Trouble shooting.....	94
Chapter 6 Maintenance	96
6.1 Inspection	96
6.2 Periodic Maintenance.....	97
6.3 Replacement of wearing parts.....	98
Chapter 7 Peripheral Devices Selection.....	99
7-1 Peripheral Devices Description	99
7-2 Applied DC reactor Specification.....	100
7-3 Applied AC reactor Specification	101
7-4 Applied Braking resistor Specification	103
Appendix A.....	106
Appendix B.....	128

Chapter 1 Introduction

1.1 Technology Features

• Input & Output

- ◆ Input Voltage Range: 220/380/660V±15%
- ◆ Input Frequency Range: 47~63Hz
- ◆ Output Voltage Range: 0~rated input voltage
- ◆ Output Frequency Range: 0~600Hz

• I/O Features

- ◆ Programmable Digital Input: Provide 7 terminals which can support ON-OFF inputs, 1 terminal which can support high speed pulse input and support PNP, NPN
- ◆ Programmable Analog Input: FIV can accept input of -10V ~10V, FIC can accept input of 0~10V or 0~20mA.
- ◆ Programmable Open Collector Output: Provide 1 output terminal (open collector output or high speed pulse output)
- ◆ Relay Output: Provide 2 output terminals(Which one is optional)
- ◆ Analog Output: Provide 2 output terminal(FOV/FOC), whose output scope can be 0/4~20 mA or 0~10 V, as chosen.

• Main Control Function

- ◆ Control Mode: V/F control, Sensorless Vector Control (SVC)
- ◆ Overload Capacity: 60s with 150% of rated current, 10s with 180% of rated current.
- ◆ Speed Adjusting Range: 1:100 (SVC)
- ◆ Carrier Frequency: 1 kHz ~15.0 kHz. (Need derating if higher than default setting)
- ◆ Frequency reference source: keypad, analog input, X8, serial

communication, multi-step speed, simple PLC and PID. The combination of multi-modes and the switch between different modes can be realized.

- ◆ PID Control Function
- ◆ Simple PLC, Multi-Steps Speed Control Function: 16 steps speed can be set.
- ◆ Traverse Control Function.
- ◆ None-Stop when instantaneous power off.
- ◆ Speed Trace Function: Smoothly start the running motor.
- ◆ JOG Key: User defined shortcut key can be realized.
- ◆ Automatic Voltage Regulation Function (AVR).
- ◆ Automatically keep the output voltage stable when input voltage fluctuating.
- ◆ Up to 25 fault protections: Protect from over current, over voltage, under voltage, over temperature, phase failure, over load etc.

MODEL: H6400S-1R5G/2R2P

INPUT: 3PH 380V 50Hz/60Hz

OUTPUT: 3PH 380V 3.7/5.0A

FREQ RANGE: 0.1--600Hz 1.5/2.2kw



1404000001



Model: H 6400S - 1R5G/2R2P

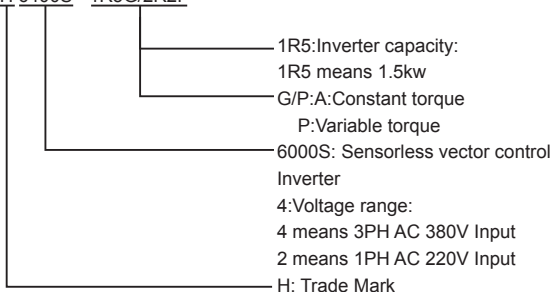

1.2 Description of Name Plate

1.3 Selection Guide

1.3PH AC380V±15%/1PH AC220V±15%

Model No.	Rated Output Power (KW)	Rated Input current (A)	Rated Output Current (A)	Motor Power (KW)
1PH/3PH AC 220V -15%~15%				
H6200S-0R4G	0.4	5.4	2.3	0.4
H6200S-0R7G	0.75	8.2	4.5	0.75
H6200S-1R5G	1.5	14.2	7.0	1.5
H6200S-2R2G	2.2	23.0	10	2.2
H6200S-3R7G	3.7	35.0	16	3.7
3PH AC380V±15%				
H6400S-0R4G/0R7P	0.4/0.75	3.4/3.8	1.2/2.5	0.4/0.75
H6400S-0R7G/1R5P	0.75/1.5	3.8/5.0	2.5/3.7	0.75/1.5
H6400S-1R5G/2R2P	1.5/2.2	5.0/5.8	3.7/5.0	1.5/2.2
H6400S-2R2G/3R7P	2.2/3.7	5.8/10.0	5.0/9.0	2.2/3.7
H6400S-3R7G/5R5P	3.7/5.5	10.0/15.0	9.0/13.0	3.7/5.5
H6400S-5R5G/7R5P	5.5/7.5	15.0/20.0	13.0/17.0	5.5/7.5
H6400S-7R5G/11P	7.5/11	20.0/26.0	17.0/25.0	7.5/11
H6400S-11G/15P	11/15	26.0/35.0	25.0/32.0	11/15
H6400S-15G/18.5P	15/18.5	35.0/38.0	32.0/37.0	15/18.5
H6400S-18.5G/22P	18.5/22	38.0/46.0	37.0/45.0	18.5/22
H6400S-22G/30P	22/30	46.0/62.0	45.0/60.0	22/30
H6400S-30G/37P	30/37	62.0/76.0	60.0/75.0	30/37
H6400S-37G/45P	37/45	76.0/90.0	75.0/90.0	37/45
H6400S-45G/55P	45/55	90.0/105.0	90.0/110.0	45/55
H6400S-55G	55	105.0	110.0	55
H6400S-75P	75	140.0	150.0	75
H6400S-75G/90P	75/90	140.0/160.0	150.0/176.0	75/90
H6400S-90G/110P	90/110	160.0/210.0	176.0/210.0	90/110
H6400S-110G/132P	110/132	210.0/240.0	210.0/253.0	110/132
H6400S-132G/160P	132/160	240.0/290.0	253.0/300.0	132/160
H6400S-160G/185P	160/185	290.0/330.0	300.0/340.0	160/185
H6400S-185G/200P	185/200	330.0/370.0	340.0/380.0	185/200
H6400S-200G/220P	200/220	370.0/410.0	380.0/420.0	200/220
H6400S-220G/250P	220/250	410.0/460.0	420.0/470.0	220/250
H6400S-250G/280P	250/280	460.0/500.0	470.0/520.0	250/280
H6400S-280G/315P	280/315	500.0/580.0	520.0/600.0	280/315

Operation Instruction of H6000S Series Inverter

Model No.	Rated Output Power (KW)	Rated Input current (A)	Rated Output Current (A)	Motor Power (KW)
H6400S-315G/350P	315/350	580.0/620.0	600.0/640.0	315/350
H6400S-350G/400P	350/400	620.0/670.0	640.0/690.0	350/400
H6400S-400G/450P	400/450	670.0/790.0	690.0/790.0	400/450
H6400S-450G/500P	450/500	790.0/835.0	790.0/860.0	450/500
H6400S-500G/560P	500/560	835.0/920.0	860.0/950.0	500/560
H6400S-560G/630P	560/630	920.0/1050.0	950.0/1100.0	560/630
H6400S-630G/710P	630/710	1050.0/1126.0	1100.0/1280.0	630/710
H6400S-710G/800P	710/800	1126.0/1460.0	1280.0/1380.0	710/800
H6400S-800G/900P	800/900	1460.0/1640.0	1380.0/1640.0	800/900
H6400S-900G/1000P	900/1000	1640.0/1800.0	1640.0/1720.0	900/1000
H6400S-1000G	1000	1800.0	1720.0	1000

2.3PH AC660V±15%

Model No.	Rated Output Power (KW)	Rated Input current (A)	Rated Output Current (A)	Motor Power (KW)
H6600S-11G/15P	11/15	13/19	16/20	11/15
H6600S-15G/18.5P	15/18.5	19/28	20/25	15/18.5
H6600S-18.5G/22P	18.5/22	28/38	25/28	18.5/22
H6600S-22G/30P	22/30	38/40	28/35	22/30
H6600S-30G/37P	30/37	40/47	35/45	30/37
H6600S-37G/45P	37/45	47/55	45/52	37/45
H6600S-45G/55P	45/55	55/65	52/63	45/55
H6600S-55G/75P	55/75	65/85	63/86	55/75
H6600S-75G/90P	75/90	85/95	86/98	75/90
H6600S-90G/110P	90/110	95/118	98/121	90/110
H6600S-110G/132P	110/132	118/145	121/150	110/132
H6600S-132G/160P	132/160	145/165	150/175	132/160
H6600S-160G/185P	160/185	165/190	175/198	160/185
H6600S-185G/200P	185/200	190/210	198/218	185/200
H6600S-200G/220P	200/220	210/230	218/240	200/220
H6600S-220G/250P	220/250	230/255	240/270	220/250
H6600S-250G/280P	250/280	255/290	270/320	250/280
H6600S-280G/315P	280/315	290/334	320/350	280/315
H6600S-315G/350P	315/350	334/360	350/380	315/350
H6600S-350G/400P	350/400	360/411	380/430	350/400
H6600S-400G/450P	400/450	411/480	430/480	400/450
H6600S-450G/500P	450/500	480/518	480/540	450/500

Model No.	Rated Output Power (KW)	Rated Input current (A)	Rated Output Current (A)	Motor Power (KW)
H6600S-500G/560P	500/560	518/578	540/600	500/560
H6600S-560G/630P	560/630	578/655	600/680	560/630
H6600S-630G/710P	630/710	655/750	680/750	630/710
H6600S-710G/800P	710/800	750/850	750/860	710/800

1.4 Inverter outline dimension drawings

(1) wall mounting

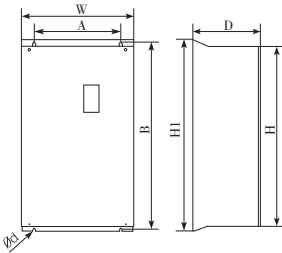

(2) cabinet installation

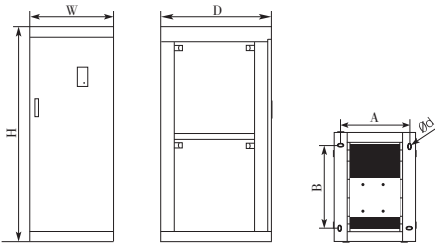

Model	Outline dimension				Installation size			Unit:mm	
	W	H	H1	D	A	B	ød	Installation	Remark
H6200S-0R4G	125	170	-	140	117	160	5	Wall hanging	All plastic
H6200S-0R7G									
H6200S-1R5G									
H6200S-2R2G									
H6200S-3R7G	120	225	-	143	105	208	5		Semi plastic

Operation Instruction of H6000S Series Inverter

Model	Outline dimension				Installation size			Unit:mm		
	W	H	H1	D	A	B	∅d	Installation	Remark	
H6400S-0R4G/0R7P	125	170	-	140	117	160	5	Wall hanging	All plastic	
H6400S-0R7G/1R5P										
H6400S-1R5G/2R2P										
H6400S-2R2G/3R7P										
H6400S-3R7G/5R5P	120	225	-	143	105	208	5		Semi plastic	
H6400S-5R5G/7R5P	185	260	-	170	168	248	6.5		All plastic	
H6400S-7R5G/11P										
H6400S-11G/15P	210	330	-	190	195	310	6		Semi plastic	
H6400S-15G/18.5P										
H6400S-18.5G/22P	277	410	-	189	262	390	5			
H6400S-22G/30P										
H6400S-30G/37P										
H6400S-37G/45P	300	430	455	212	200	435	5			Iron shell
H6400S-45G/55P	300	535	560	236	200	538	9			
H6400S-55G/75P										
H6400S-75G/90P	380	625	650	252	250	625	9			
H6400S-90G/110P										
H6400S-110G/132P	420	730	790	330	300	765	11			
H6400S-132G/160P										
H6400S-160G/185P										
H6400S-185G/200P	530	800	860	335	400	835	13	wall hanging or floor mounted		
H6400S-200G/220P										
H6400S-220G/250P										
H6400S-250G/280P	700	880	940	335	600	915	11			
H6400S-280G/315P										
H6400S-315G/350P	600	1550	-	800	500	600	13		Iron shell	
H6400S-350G/400P										
H6400S-400G/450P										
H6400S-450G/500P	650	1550	-	800	550	600	13			
H6400S-500G/560P										
H6400S-560G/630P										
H6400S-630G/710P	700	2200	-	1000	600	800	13			
H6400S-710G/800P										
H6400S-800G/900P										
H6400S-900G/1000P										
H6400S-1000G										

Dimension of the keyboard for above 5.5KW:141.5mm*79.5mm

Dimension of the keyboard for below 3.7KW:99.5mm*56mm

1.5. INSPECTION



CAUTION

- Don't install or use any inverter that is damaged or have fault part, otherwise may cause injury.

Check the following items when unpacking the inverter,

1. Inspect the entire exterior of the Inverter to ensure there are no scratches or other damage caused by the transportation.
2. Ensure there is operation manual and warranty card in the packing box.
3. Inspect the nameplate and ensure it is what you ordered.
4. Ensure the optional parts are what you need if have ordered any optional parts.

Please contact the local agent if there is any damage in the inverter



WARNING

- The person without passing the training manipulate the device or any rule in the "Warning" being violated, will cause severe injury or property loss. Only the person, who has passed the training on the design, installation, commissioning and operation of the device and gotten the certification, is permitted to operate this equipment.
- Input power cable must be connected tightly, and the equipment must be grounded securely.
- Even if the inverter is not running, the following terminals still have dangerous voltage:
 - Power Terminals: R, S, T
 - Motor Connection Terminals: U, V, W.
- When power off, should not install the inverter until 5 minutes after, which can ensure the device discharge completely.
- The section area of grounding conductor must be no less than that of power supply cable.



CAUTION

- When moving the inverter please lift by its base and don't lift by the panel. Otherwise may cause the main unit fall off which may result in personal injury.
- Install the inverter on the fireproofing material (such as metal) to prevent fire.
- When need install two or more inverters in one cabinet, cooling fan should be provided to make sure that the air temperature is lower than 45°C. Otherwise it could cause fire or damage the device.

or optional parts.

1.6. INSTALLATION

1.7 Environmental Requirement

1. Temperature

Environment temperature range: -10°C ~ +40°C. Inverter will be derated if ambient temperature exceeds 40°C.

2. Humidity

Less than 95% RH, without dewfall.

3. Altitude

Inverter can output the rated power when installed with altitude of lower than 1000m. It will be derated when the altitude is higher than 1000m. For details, please refer to the following figure:

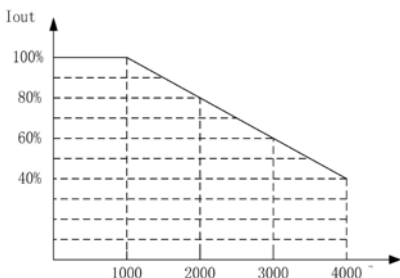

Figure 3.1 Relationship between output current and altitude.

4. Impact and Vibration

It is not allowed that the inverter falls down or suffers from fierce impact or the inverter installed at the place that vibration frequently.

5. Electromagnetic Radiation

Keep away from the electromagnetic radiation source.

6. Water

Do not install the inverter at the wringing or dewfall place.

7. Air Pollution

Keep away from air pollution such as dusty, corrosive gas.

8. Storage

Do not store the inverter in the environment with direct sunlight, vapor, oil fog and vibration.

1.8 Installation Space

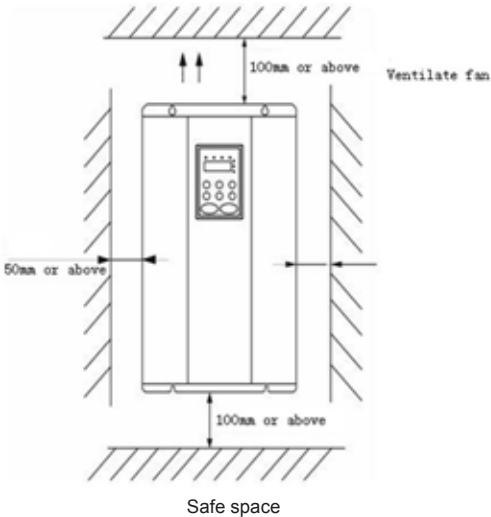

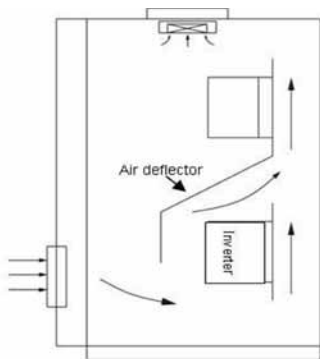

Installation of multiple inverters.

Notice: Add the air deflector when apply the up-down installation.

Chapter 2 Wiring

2.1 Connection of Peripheral Devices

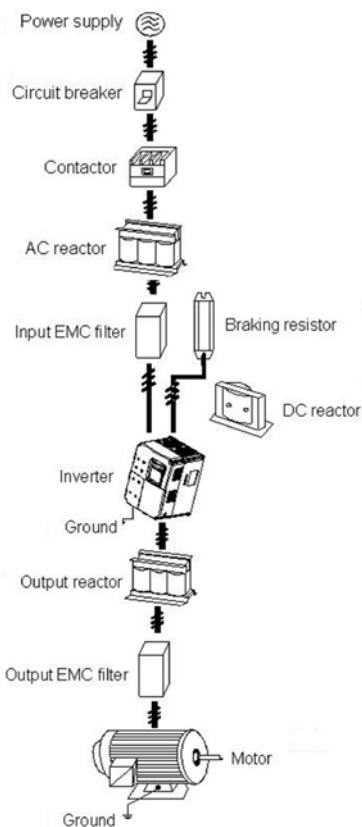

2.2 Terminal Configuration

2.2.1 Main Circuit Terminals

1. Main circuit terminals (3PH AC 380V 0.75~3.7kW).

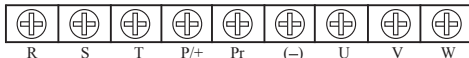

2. Main circuit terminals (3PH AC 380V 5.5~7.5kW).

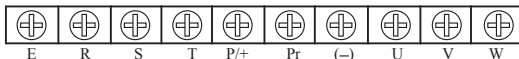

3. Main circuit terminals (3PH AC 380V 11~15kW).

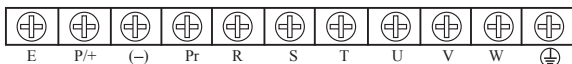

4. Main circuit terminals (3PH AC 380V 18.5~110kW).

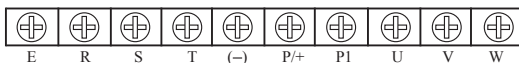

5. Main circuit terminals (3PH AC 380V 18.5~37kW The brake unit is built-in).

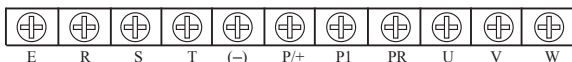

6. Main circuit terminals(3PH AC 380V 132--315kW)

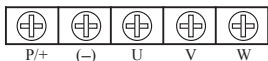
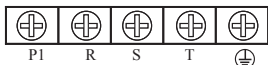

7. Main circuit terminals(3PH AC 380V 350kW or more)

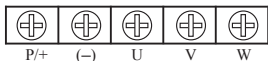
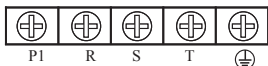

NOTE: "710--1000kW ,Top row, the front door wiring,
Second row from the back door wiring "

Main circuit terminal functions are summarized according to the terminal symbols in the following table. Wire the terminal correctly for the desired purposes.

Terminal Symbol	Description
R, S, T	Terminals of 3 phase AC input
P, (-)	Spare terminals of external braking unit
P, Pr	Spare terminals of external braking resistor
P1, P/+	Spare terminals of external DC reactor
(-)	Terminal of negative DC bus
U, V, W	Terminals of 3 phase AC output
	Terminal of ground

2.2.2 Control Circuit Terminals (Optional)

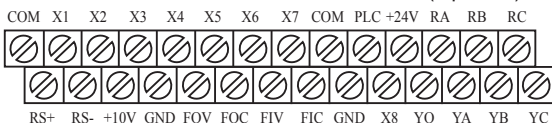

Terminal	Description
X1~X7	ON-OFF signal input, optical coupling with PLC and COM Input voltage range: 9~30V Input impedance: 3.3kΩ
X8	High speed pulse or ON-OFF signal input, optical coupling with PLC and COM. Pulse input frequency range: 0~50kHz Input voltage range: 9~30V Input impedance: 1.1kΩ
PLC	external power supply. +24V terminal is connected to PLC terminal as default setting. If user need external power supply, disconnect +24V terminal with PW terminal and connect PLC
+24V	terminal with external power supply. Provide output power supply of +24V. Maximum output current: 150mA
FIV	Analog input, -10V~10V Input impedance: 20kΩ
FIC	Analog input, 0~10V/ 0~20mA, switched by J3. Input impedance: 10kΩ (voltage input) / 250Ω (current input)
GND	Common ground terminal of analog signal and +10V. GND must isolated from COM.
+10V	Supply +10V for inverter. High speed pulse output terminal. The corresponding common
YO	ground terminal is COM. Output frequency range: 0~50 kHz

Terminal	Description
COM	Common ground terminal for digital signal and +24V (or external power supply).
FOV/FOC	Provide voltage or current output which can be switched by J4 and J1. Output range: 0~10V/ 0~20mA
RA/RB/RC (Optional)	Relay output: RC-common;RB-NC;RA-NO(Optional) . Contact capacity: AC 250V/3A, DC 30V/1A.
YA/YB/YC	Relay output: YC—common; YB—NC; YA—NO. Contact capacity: AC 250V/3A, DC 30V/1A.
RS+,RS-	485 communication port. 485 differential signal, +,-.

2.3 Wiring Diagram

Typical Wiring Diagram

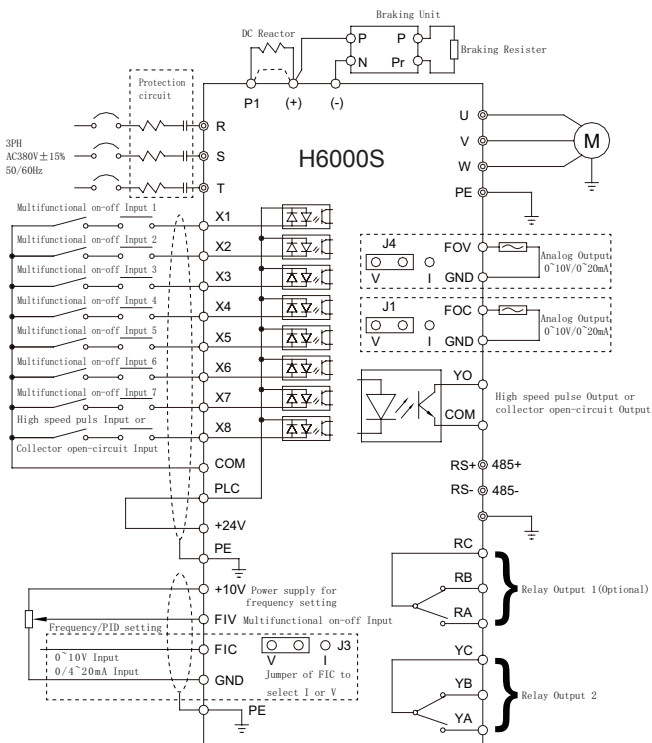

2.4 Wiring Main Circuits

2.4.1 Wiring at input side of main circuit

2.4.1.1 Circuit breaker

It is necessary to connect a circuit breaker which is compatible with the capacity of inverter between 3ph AC power supply and power input terminals (R, S, T). The capacity of breaker is 1.5~2 times to the rated current of inverter. For details, see <Specifications of Breaker, Cable, and Contactor>.

2.4.1.2 Contactor

In order to cut off the input power effectively when something is wrong in the system, contactor should be installed at the input side to control the ON-OFF of the main circuit power supply.

2.4.1.3 AC reactor

In order to prevent the rectifier damage result from the large current, AC reactor should be installed at the input side. It can also prevent rectifier from sudden variation of power voltage or harmonic generated by phase-control load.

2.4.1.4 Input EMC filter

The surrounding device may be disturbed by the cables when the inverter is working. EMC filter can minimize the interference. Just like the following figure.

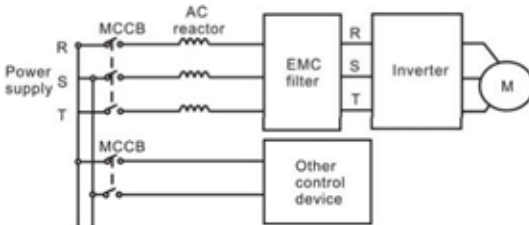

Wiring at input side.

2.4.2 Wiring at inverter side of main circuit

2.4.2.1 DC reactor

Inverters above 250kw have built-in DC reactor which can improve the power factor,

2.4.2.2 Braking unit and braking resistor

- Inverter of 15KW and below have built-in braking unit. In order to dissipate the regenerative energy generated by dynamic braking, the braking resistor should be installed at (+) and Pr terminals. The wire length of the braking resistor should be less than 5m.
- Inverter of 18.5KW and above need connect external braking unit which should be installed at (+) and (-) terminals. The cable between inverter and braking unit should be less than 5m. The cable between braking unit and braking resistor should be less than 10m.
- The temperature of braking resistor will increase because the regenerative energy will be transformed to heat. Safety protection and good ventilation is recommended.

Notice: Be sure that the electric polarity of (+) (-) terminals is right; it is not allowed to connect (+) with (-) terminals directly, Otherwise damage or fire may occur.

2.4.3 Wiring at motor side of main circuit

2.4.3.1 Output Reactor

Output reactor must be installed in the following condition. When the distance between inverter and motor is more than 50m, inverter may be tripped by over-current protection frequently because of the large leakage current resulted from the parasitic capacitance with ground. And the same time to avoid the damage of motor insulation, the output reactor should be installed.

2.4.3.2 Output EMC filter

EMC filter should be installed to minimize the leakage current caused by the cable and minimize the radio noise caused by the cables between the inverter and cable. Just see the following figure.

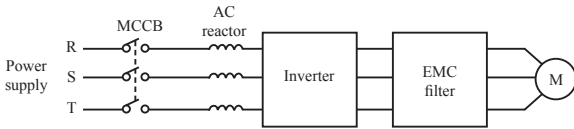

Wiring at motor side.

2.4.4 Wiring of regenerative unit

Regenerative unit is used for putting the electricity generated by braking of motor to the grid. Compared with traditional 3 phase inverse parallel bridge type rectifier unit, regenerative unit uses IGBT so that the total harmonic distortion (THD) is less than 4%. Regenerative unit is widely used for centrifugal and hoisting equipment.

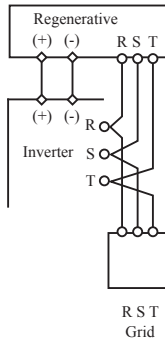

Wiring of regenerative unit.

2.4.5 Wiring of Common DC bus

Common DC bus method is widely used in the paper industry and chemical fiber industry which need multi-motor to coordinate. In these applications, some motors are in driving status while some others are in regenerative braking (generating electricity) status. The regenerated energy is automatically balanced through the common DC bus, which means it can supply to motors in driving

status. Therefore the power consumption of whole system will be less compared with the traditional method (one inverter drives one motor).

When two motors are running at the same time (i.e. winding application), one is in driving status and the other is in regenerative status. In this case the DC buses of these two inverters can be connected in parallel so that the regenerated energy can be supplied to motors in driving status whenever it needs. Its detailed wiring is shown in the following figure:

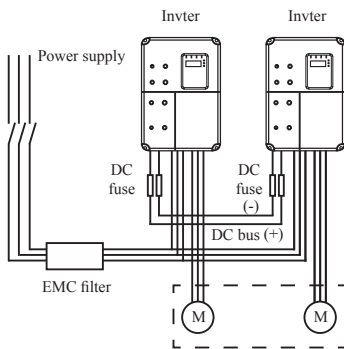

Wiring of common DC bus.

Notice: Two inverters must be the same model when connected with Common DC bus method. Be sure they are powered on at the same time.

2.4.6 Ground Wiring (PE)

In order to ensure safety and prevent electrical shock and fire, terminal PE must be grounded with ground resistance. The ground wire should be big and short, and it is better to use copper wire ($>3.5\text{mm}^2$). When multiple inverters need to be grounded, do not loop the ground wire.

2.5 Installation Guidline to EMC Compliance

2.5.1 General knowledge of EMC

EMC is the abbreviation of electromagnetic compatibility, which means the device or system has the ability to work normally in the electromagnetic environment and will not generate any electromagnetic interference to other equipments.

EMC includes two subjects: electromagnetic interference and electromagnetic anti-jamming.

According to the transmission mode, Electromagnetic interference can be divided into two categories: conducted interference and radiated interference.

Conducted interference is the interference transmitted by conductor. Therefore, any conductors (such as wire, transmission line, inductor, capacitor and so on) are the transmission channels of the interference.

Radiated interference is the interference transmitted in electromagnetic wave, and the energy is inverse proportional to the square of distance.

Three necessary conditions or essentials of electromagnetic interference are: interference source, transmission channel and sensitive receiver. For customers, the solution of EMC problem is mainly in transmission channel because of the device attribute of disturbance source and receiver can not be changed.

2.5.2 EMC features of inverter

Like other electric or electronic devices, inverter is not only an electromagnetic interference source but also an electromagnetic receiver. The operating principle of inverter determines that it can produce certain electromagnetic interference noise. At the same time inverter should be designed with certain anti-jamming ability to ensure the smooth working in certain electromagnetic environment. Following is its EMC features:

2.5.2.1 Input current is non-sine wave. The input current

includes large amount of high-harmonic waves that can cause electromagnetic interference, decrease the grid power factor and increase the line loss.

2.5.2.2 Output voltage is high frequency PWM wave, which can increase the temperature rise and shorten the life of motor. And the leakage current will also increase, which can lead to the leakage protection device malfunction and generate strong electromagnetic interference to influence the reliability of other electric devices.

2.5.2.3 As the electromagnetic receiver, too strong interference will damage the inverter and influence the normal using of customers.

2.5.2.4 In the system, EMS and EMI of inverter coexist. Decrease the EMI of inverter can increase its EMS ability.

2.5.3 EMC Installation Guideline

In order to ensure all electric devices in the same system to work smoothly, this section, based on EMC features of inverter, introduces EMC installation process in several aspects of application (noise control, site wiring, grounding, leakage current and power supply filter). The good effective of EMC will depend on the good effective of all of these five aspects.

2.5.3.1 Noise control

All the connections to the control terminals must use shielded wire. And the shield layer of the wire must ground near the wire entrance of inverter. The ground mode is 360 degree annular connection formed by cable clips. It is strictly prohibitive to connect the twisted shielding layer to the ground of inverter, which greatly decreases or loses the shielding effect.

Connect inverter and motor with the shielded wire or the separated cable tray. One side of shield layer of shielded wire or metal cover of separated cable tray should connect to ground, and the other side should connect to the motor cover. Installing an EMC filter can reduce the electromagnetic noise greatly.

2.5.3.2 Site wiring

Power supply wiring: the power should be separated supplied from electrical transformer. Normally it is 5 core wires, three of which are fire wires, one of which is the neutral wire, and one of which is the ground wire. It is strictly prohibitive to use the same line to be both the neutral wire and the ground wire.

Device categorization: there are different electric devices contained in one control cabinet, such as inverter, filter, PLC and instrument etc, which have different ability of emitting and withstanding electromagnetic noise. Therefore, it needs to categorize these devices into strong noise device and noise sensitive device. The same kinds of device should be placed in the same area, and the distance between devices of different category should be more than 20cm.

Wire Arrangement inside the control cabinet: there are signal wire (light current) and power cable (strong current) in one cabinet. For the inverter, the power cables are categorized into input cable and output cable. Signal wires can be easily disturbed by power cables to make the equipment malfunction. Therefore when wiring, signal cables and power cables should be arranged in different area. It is strictly prohibitive to arrange them in parallel or interlacement at a close distance (less than 20cm) or tie them together. If the signal wires have to cross the power cables, they should be arranged in 90 angles. Power input and output cables should not either be arranged in interlacement or tied together, especially when installed the EMC filter. Otherwise the distributed capacitances of its input and output power cable can be coupling each other to make the EMC filter out of function.

2.5.3.3 Ground

Inverter must be ground safely when in operation. Grounding enjoys priority in all EMC methods because it does not only ensure the safety of equipment and persons, but also is the simplest, most

effective and lowest cost solution for EMC problems.

Grounding has three categories: special pole grounding, common pole grounding and series-wound grounding. Different control system should use special pole grounding, and different devices in the same control system should use common pole grounding, and different devices connected by same power cable should use series-wound grounding.

2.5.3.4 Leakage Current

Leakage current includes line-to-line leakage current and over-ground leakage current.

Its value depends on distributed capacitances and carrier frequency of inverter. The over-ground leakage current, which is the current passing through the common ground wire, can not only flow into inverter system but also other devices. It also can make leakage current circuit breaker, relay or other devices malfunction. The value of line-to-line leakage current, which means the leakage current passing through distributed capacitors of input output wire, depends on the carrier frequency of inverter, the length and section areas of motor cables. The higher carrier frequency of inverter, the longer of the motor cable and/or the bigger cable section area, the larger leakage current will occur.

Countermeasure:

Decreasing the carrier frequency can effectively decrease the leakage current. In the case of motor cable is relatively long (longer than 50m), it is necessary to install AC reactor or sinusoidal wave filter at the output side, and when it is even longer, it is necessary to install one reactor at every certain distance.

2.5.3.5 EMC Filter

EMC filter has a great effect of electromagnetic decoupling, so it is preferred for customer to install it.

For inverter, noise filter has following categories:

- Noise filter installed at the input side of inverter;



- Install noise isolation for other equipment by means of isolation transformer or power filter.



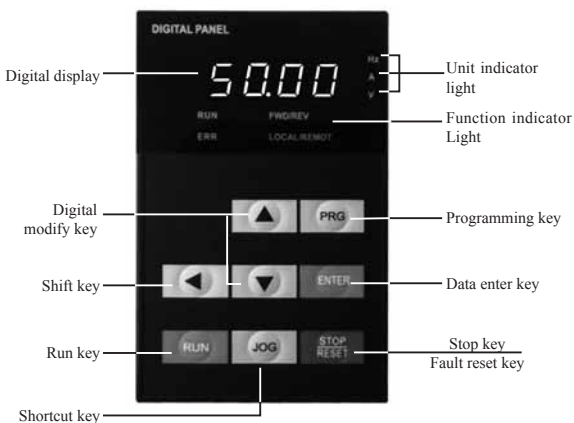



Chapter 3 Operation

3.1 Keypad Description



3.2 Function key description

Key	Name	Description
	Programming key	Entry or escape of first-level menu
	Data enter key	Progressively enter menu and confirm parameters.
	UP Increment Key	Progressively increase data or function codes.

Key	Name	Description
	DOWN Decrement Key	Progressive decrease data or function codes.
	Right shift Key	In parameter setting mode, press this button to select the bit to be modified. In other modes, cyclically displays parameters by right shift
	Run key	Start to run the inverter in keypad control mode.
	Stop key/Fault reset key	In running status, restricted by F7.04, can be used to stop the inverter. When fault alarm, can be used to reset the inverter without any restriction.
	Shortcut Key	Determined by Function Code F7.03: 0: Display status switching 1: Jog operation 2: Switch between forward and reverse 3: Clear the UP/DOWN settings. 4: Quick debugging mode
	Combination Key	Pressing the RUN and STOP/RST at the same time can achieve inverter coast to stop.

3.3 Indicator light description

1) Function Indicator Light Description

Indicator Light Name	Indicator Light Description
FWD/REV	Extinguished: forward operation Light on: reverse operation.
LOCAL/REMOT	Extinguished: keypad control Flickering: terminal control Light on: communication control

2) Unit Indicator Light Description

Symbol	Description
Hz	Frequency unit
A	Current unit
V	Voltage unit

3) Digital Display

Have 5 digit LED, which can display all kinds of monitoring data and alarm codes such as reference frequency, output frequency and so on.

3.4 Operation Process

3.4.1 Parameter setting

Three levels of menu are:

1. Function code group (first-level);
2. Function code (second-level);
3. Function code value (third-level).

Remarks:

Press both the PRG and the ENTER can return to the second-class menu from the third-class menu. The difference is: pressing PRG will save the set parameters into the control panel, and then return to the second-class menu with shifting to the next function code automatically; while pressing ENTER will directly return to the second-class menu without saving the parameters, and keep staying at the current function code.

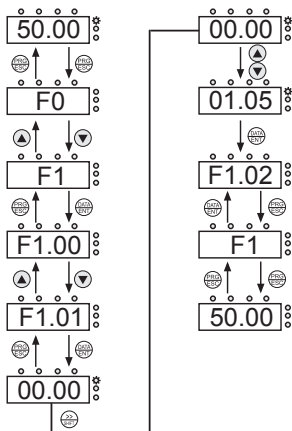

Flow chart of parameter setting.

Under the third-class menu, if the parameter has no flickering bit, it means the function code cannot be modified. The possible reasons could be:

- 1) This function code is not modifiable parameter, such as actual detected parameter, operation records and so on;
- 2) This function code is not modifiable in running status, but modifiable in stop status

3.4.2 Fault reset

If the inverter has fault, it will prompt the related fault information. User can use STOP or according terminals determined by F4 Group to reset the fault. After fault reset, the inverter is at stand-by state. If user does not reset the inverter when it is at fault state, the inverter will be at operation protection state, and can not run.

3.4.3 Motor parameter autotuning

If "Sensorless Vector Control" mode is chosen, motor nameplate parameters must be input correctly as the autotuning is based on it. The performance of vector control depends on the parameters of motor strongly, so to achieve excellent performance, firstly must obtain the parameter of motor exactly.

The procedure of motor parameter autotuning is as follows:

Firstly, choose the keypad command channel as the operation command channel (F0.02).

And then input following parameters according to the actual motor parameters:

F1.00: motor rated power.

F1.01: motor rated frequency;

F1.02: motor rated speed;

F1.03: motor rated voltage;

F1.04: motor rated current

Notice: the motor should be uncoupled with its load; otherwise, the motor parameters obtained by autotuning may be not correct.

Set F0.18 to be 1, and for the detail process of motor parameter autotuning, please refer to the description of Function Code F0.18. And then press RUN on the keypad panel, the inverter will automatically calculate following parameter of the motor:

F1.05: motor stator resistance;

F1.06: motor rotor resistance;

F1.07: motor stator and rotor inductance;

F1.08: motor stator and rotor mutual inductance;

F1.09: motor current without load;

then motor autotuning is finished.

3.4.4 Password setting

H6000S series inverter offers user's password protection function. When F7.00 is set to be nonzero, it will be the user's password, and After exiting function code edit mode, it will become effective after 1 minute. If pressing the PRG again to try to access the function code edit mode, "0.0.0.0.0" will be displayed, and the operator must input correct user's password, otherwise will be unable to access it. If it is necessary to cancel the password protection function, just set F7.00 to be zero.

3.5 Running State

3.5.1 Power-on initialization

Firstly the system initializes during the inverter power-on, and LED displays "-H6000S-". After the initialization is completed, the inverter is on stand-by status.

3.5.2 Stand-by

At stop or running status, parameters of multi-status can be displayed. Whether or not to display this parameter can be chosen through Function Code F7.06(Running status display selection) and F7.07 (Stop status display selection) according to binary bits,

the detailed description of each bit please refer the function code description of F7.06 and F7.07.

In stop status, there are nine parameters which can be chosen to display or not. They are: reference frequency, DC bus voltage, ON-OFF input status, open collector output status, PID setting, PID feedback, analog input FIV voltage, analog input FIC voltage, step number of multi-step speed. Whether or not to display can be decided by setting the corresponding binary bit of F7.07. Press the \rightarrow to scroll through the parameters in right order. Press ENTER + JOG to scroll through the parameters in left order.

3.5.3 Motor parameter autotuning

For details, please refer to the description of F0.18.

3.5.4 Operation

In running status, there are fourteen running parameters: output frequency, reference frequency, DC bus voltage, output voltage, output current, output power, output torque, PID setting, PID feedback, ON-OFF input status, open collector output status, length value, count value, step number of PLC and multi-step speed, voltage of FIV, voltage of FIV and step number of multi-step speed. Whether or not to display can be decided by the bit option of Function Code F7.06 (converted into binary system). Press the \rightarrow to scroll through the parameters in right order. Press ENTER + JOG to scroll through the parameters in left order.

3.5.5 Fault

H6000S series inverter offers a variety of fault information. For details, see inverter faults and their troubleshooting.

3.6 Quick Testing

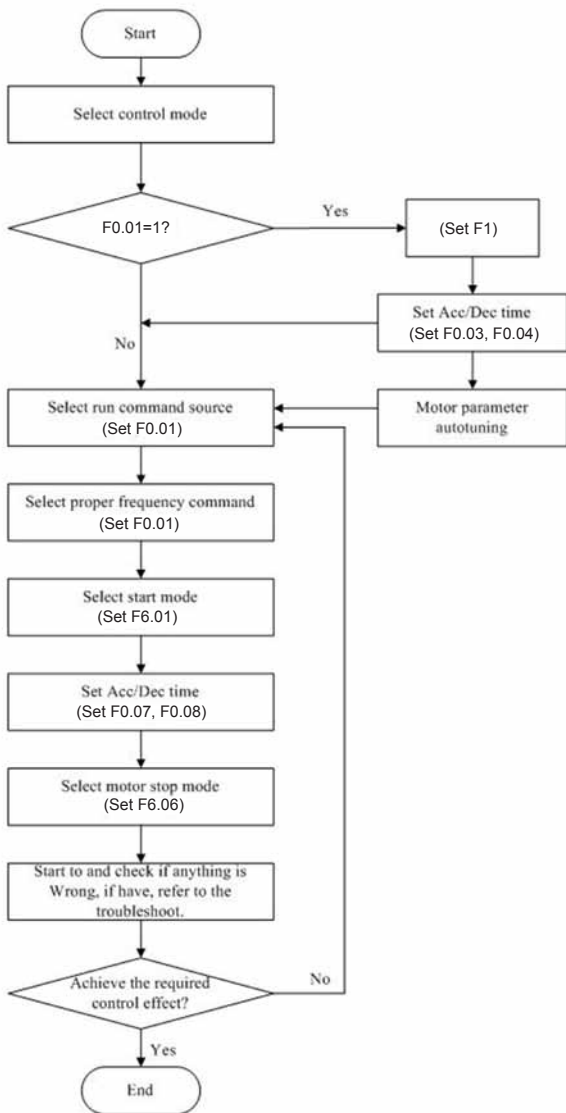

Chapter 4

Detailed Function Description

4.1 F0 Group--Basic Function

Function Code	Name	Description	Setting Range	Factory setting
F0.00	Inverter model	0: G model 1: P model	0--1	Depend on Mode

0: G model: Applicable to constant torque load.

1: P model: Applicable to constant power load.

Function Code	Name	Description	Setting Range	Factory setting
F0.01	Control model	0: V/F control 1: Sensorless vector control 2: Torque control (sensorless vector control)	0--2	0

0: V/F control: It is suitable for general purpose application such as pumps, fans etc.

1: Sensorless vector control: It is widely used for the application which requires high torque at low speed, high speed accuracy, and quicker dynamic response, such as machine tool, injection molding machine, centrifugal machine and wire-drawing machine, etc.

2. Torque control: It is suitable for the application with low accuracy torque control, such as wire-drawing.

Notice:

• **The autotuning of motor parameters must be accomplished properly if you use the sensorless vector control mode or Torque control mode. How to autotuning of motor parameters please refer to page 37.**

● **In order to achieve better control characteristic, the parameters of vector control (F2 Group) should be adjusted.**

Function Code	Name	Description	Setting Range	Factory setting
F0.02	Run command source	0:Keypad (LEDextinguished) 1:Terminal (LEDflickering) 2: Communication (LEDlights on)	0–2	0

The control commands of inverter include: start, stop, forward run, reverse run, jog, fault reset and so on.

0: Keypad (LED extinguished);

Both RUN and STOP/RST key are used for running command control. If Multifunction key JOG is set as FW D/REV switching function (F7.03 is set to be 2), it will be used to change the rotating orientation. **In running status, pressing RUN and STOP/RST in the same time will cause the inverter coast to stop.**

1: Terminal (LED flickering)

The operation, including forward run, reverse run, forward jog, reverse jog etc. can be controlled by multifunctional input terminals.

2: Communication (LED lights on)

The operation of inverter can be controlled by host through communication.

Function Code	Name	Description	Setting Range	Factory setting
F0.03	Frequency command selection	0:X; 1:Y; 2:X+Y; 3:MAX(X,Y)	0–3	0

This parameter can be used to select the reference frequency command.

0: Only frequency command source X is active.

1: Only Frequency command source Y is active.

2: Both Frequency command source X and Y are active.

Reference frequency = reference frequency X + reference frequency Y.

3: Both Frequency command source X and Y are active.

Reference frequency = Max (reference frequency X, reference frequency Y).

Function Code	Name	Description	Setting Range	Factory setting
F0.04	Frequency X command source	0:Keypad; 1:FIV; 2:FIC; 3:X8; 4:Simple PLC; 5:Multi-step speed; 6:PID;7:Communication	0-7	0

0: Keypad: Please refer to description of F0.13

1: FIV

2: FIC

The reference frequency is set by analog input. FIV is -10V~10V voltage input terminal, while FIC is 0~10V/0(4)~20mA, which can be selected by J3. When FIC is selected to be 0~20mA, which corresponds with 5V.

3: X8

The reference frequency is set by high speed pulse input.

Pulse specification: pulse voltage range 15~30V, and pulse frequency range 0.0~50.0 kHz. 100% of the setting in pulse corresponds with maximal frequency, while -100% corresponds with minus maximal frequency.

4. Simple PLC

User can set reference frequency, hold time, running direction of each step and acceleration/deceleration time between steps. For details, please refer to description of FA group.

5. Multi-step speed

The reference frequency is determined by F4 and FA group. The selection of steps is determined by combination of multi-step speed terminals.

Notice:

• **Multi-step speed mode will enjoy priority in setting reference frequency if F0.04 is not set to be 4 or 5. In this case, only step**

1 to step 15 are available.

- **If F0.04 is set to be 5, step 0 to step 15 can be realized.**
- **Jog has highest priority.**

6. PID

The reference frequency is the result of PID adjustment. For details, please refer to description of F9 group.

7. Communication

The reference frequency is set through RS485. For details, please refer to Modbus protocol in AppendixB.

Function Code	Name	Description	Setting Range	Factory setting
F0.05	Frequency Y command source	0:FIV;1:FIC;2:X8	0-2	0

For details, please refer to F0.04

Function Code	Name	Description	Setting Range	Factory setting
F0.06	Scale of frequency Y command	0: Maximum frequency 1: Frequency X command	0-1	0

Notice:

- **If set FIC to be 0~20mA input, the relative voltage of 20mA is 5V. F0.06 is used when the frequency Y is superimposed.**

Function Code	Name	Description	Setting Range	Factory setting
F0.07	Acceleration time1	0.1~3600.0s	0.1~3600.0s	Depend on Mode
F0.08	Deceleration time1	0.1~3600.0s	0.1~3600.0s	Depend on Mode

Acceleration time is the time of accelerating from 0Hz to maximum frequency (F0.10). Deceleration time is the time of decelerating from maximum frequency (F0.10) to 0Hz. Please refer to following figure.

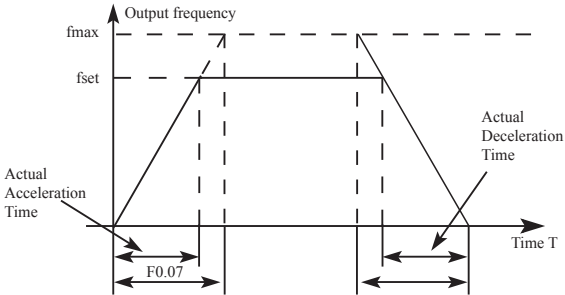

Figure 4.1 Acceleration and deceleration time

When the reference frequency is equal to the maximum frequency, the actual acceleration and deceleration time will be equal to actual setting.

When the reference frequency is less than the maximum frequency, the actual acceleration and deceleration time will be less than actual setting.

The actual acceleration (deceleration) time = setting ACC/DEC time * reference frequency / maximum frequency.

1st group: F0.07, F0.08

2nd group: F8.03, P8.04

3rd group: F8.05, F8.06

4th group: F8.07, F8.08

The acceleration and deceleration time can be selected by combination of multifunctional ON-OFF input terminals.

Function Code	Name	Description	Setting Range	Factory setting
F0.09	UP/DOWN setting	0: Valid, save UP/DOWN value when power off 1: Valid, do not save UP/DOWN value when power off 2: Invalid 3: Valid during running, clear when stop.	0--3	0

0: User can adjust the reference frequency by UP/DOWN. The

value of UP/DOWN can be saved when power off.

1: User can adjust the reference frequency by UP/DOWN, but the value of UP/DOWN

will not be saved when power off.

2: User can not adjust the reference frequency by UP/DOWN. The value of UP/DOWN will be cleared.

3: User can only adjust the reference frequency by UP/DOWN during the inverter is running. The value of UP/DOWN will be cleared when the inverter stops.

Notice:

- **UP/DOWN function can be achieved by keypad (∧ and ∨) and multifunctional terminals.**
- **Reference frequency can be adjusted by UP/DOWN.**
- **UP/DOWN has highest priority which means UP/DOWN is always active no matter which frequency command source is.**
- **When the factory setting is restored (F0.16 is set to be 1), the value of UP/DOWN will be cleared.**

Function Code	Name	Description	Setting Range	Factory setting
F0.10	Maximum frequency	10.00~600.00Hz	10.00~600.00Hz	50.00Hz

Notice: The frequency reference should not exceed maximum frequency, and it is the basis of ramping time of ACC/DEC.

Function Code	Name	Description	Setting Range	Factory setting
F0.11	Upper frequency limi	F0.12~F0.10	F0.12~F0.10	50.00Hz

Notice:

- **Upper frequency limit should exceed than the maximum frequency**
- **Output frequency should not exceed upper frequency limit.**

Function Code	Name	Description	Setting Range	Factory setting
F0.12	Lower frequency limi	0.00~F0.11	0.00~F0.11	0.00Hz

Notice:

• **Lower frequency limit should exceed than upper frequency limit (F0.11). If frequency reference is lower than F0.12, the action of inverter is determined byF6.12. Please refer to description of F6.12.**

Function Code	Name	Description	Setting Range	Factory setting
F0.13	Keypad reference frequency	0.00~F0.10	0.00~F0.10	50.00Hz

When Frequency X command source is set to be Keypad, this parameter is the initial value of inverter reference frequency

Function Code	Name	Description	Setting Range	Factory setting
F0.14	Running direction selection	0: Forward 1: Reverse 2: Forbid reverse	0-2	0

Notice:

• **If the parameters are restored, the running direction will be back to its original status.**

Function Code	Name	Description	Setting Range	Factory setting
F0.15	Carrier frequency	1.0~15.0kHz	1.0~15.0kHz	Depend on Mode

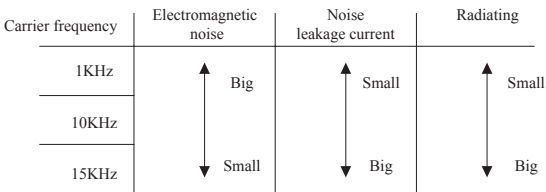

Figure 4.2 Effect of carrier frequency.

Carrier frequency will affect the noise of motor and the EMI of inverter.

If the carrier frequency is increased, it will cause better current wave, less harmonic current and lower noise of motor.

Notice:

- **The factory setting is optimal in most cases. Modification of this parameter is not recommended.**
- **If the carrier frequency exceeds the factory setting, the inverter must be derated because the higher carrier frequency will cause more switching loss, higher temperature rise of inverter and stronger electromagnetic interference.**
- **If the carrier frequency is lower than the factory setting, it is possible to cause less output torque of motor and more harmonic current.**

Function Code	Name	Description	Setting Range	Factory setting
F0.16	Restore parameters	0: No action 1: Restore factory setting 2: Clear fault records	0-2	0

0: No action

1: Inverter restores all parameters to factory setting except F1 group.

2: Inverter clear all fault records.

This function code will restore to 0 automatically when complete the function operation.

Function Code	Name	Description	Setting Range	Factory setting
F0.17	AVR function	0--2	0-2	1

Notice: AVR function is automatical debugging of output voltage

Function Code	Name	Description	Setting Range	Factory setting
F0.18	Motor parameters autotuning	0:no action; 1:Rotation autotuning; 2:Static autotuning	0--2	0

0: No action: Forbidding autotuning.

1: Rotation autotuning:

- Do not connect any load to the motor when performing autotuning and ensure the motor is in static status.
- Input the nameplate parameters of motor (F1.00 - F1.04) correctly before performing autotuning. Otherwise the parameters detected by autotuning will be incorrect; it may influence the performance of inverter.
- Set the proper acceleration and deceleration time (F0.07 and F0.08) according to the motor inertia before performing autotuning. Otherwise it may cause over-current and over-voltage fault during autotuning.
- The operation process is as follow:
 - a. Set F0.18 to be 1 then press the DATA/ENT, LED will display “-TUN-” and flickers. During “-TUN-” is flickering, press the PRG/ESC to exit autotuning.
 - b. Press the RUN to start the autotuning, LED will display “TUN-0”.
 - c. After a few seconds the motor will start to run. LED will display “TUN-1” and “RUN/TUNE” light will flicker.
 - d. After a few minutes, LED will display “-END-”. That means the autotuning is finished and return to the stop status.
 - e. During the autotuning, press the STOP/RST will stop the autotuning.

Notice:

- **Only keypad can control the autotuning. F0.18 will restore to 0 automatically when the autotuning is finished or cancelled.**

2: Static autotuning:

- If it is difficult to disconnect the load, static autotuning is recommended.
- The operation process is the same as rotation autotuning except step c.

Notice:

- **The Mutual inductance and current without load will not be detected by static autotuning, if needed user should input suitable value according to experience.**

4-2 F1 Group--Motor Parameters

Function Code	Name	Description	Setting Range	Factory setting
F1.00	Motor rated power	0.4~3000.0kW	0.4~3000.0kW	Depend on Mode
F1.01	Motor rated frequency	10.00Hz~F0.10	10.00Hz~F0.10	Depend on Mode
F1.02	Motor rated speed	0~36000rpm	0~36000 rpm	Depend on Mode
F1.03	Motor rated voltage	0~800V	0~800V	Depend on Mode
F1.04	Motor rated current	0.8~6000.0A	0.8~ 6000.0A	Depend on Mode

Notice:

- In order to achieve superior performance, please set these parameters according to motor nameplate, and then perform autotuning.
- The power rating of inverter should match the motor. If the bias is too big, the control performances of inverter will be deteriorated distinctly.
- Reset F1.00 can initialize F1.05-F1.09 automatically.

Function Code	Name	Description	Setting Range	Factory setting
F1.05	Motor stator resistance	0.001~65.535Ω	0.001~65.535Ω	Depend on Mode
F1.06	Motor rotor resistance	0.001~65.535Ω	0.001~65.535Ω	Depend on Mode
F1.07	Motor leakage inductance	0.1~6553.5mH	0.1~6553.5mH	Depend on Mode
F1.08	Motor mutual inductance;	0.1~6553.5mH	0.1~6553.5mH	Depend on Mode
F1.09	Current without load	0.01~6553.5A	0.01~6553.5A	Depend on Mode

After autotuning, the value of F1.05-F1.09 will be automatically updated.

Notice:

- Do not change these parameters, otherwise it may deteriorate the control performance of inverter.

4-3 F2 Group: Vector Control

Function Code	Name	Description	Setting Range	Factory setting
F2.00	ASR proportional gain K_p1	0~100	0~100	20
F2.01	ASR integral time K_i1	0.01~10.00s	0.01~10.00s	0.50s
F2.02	ASR switching point1			
	0.00Hz~F2.05	0.00Hz~F2.05	5.00Hz	
F2.03	ASR proportional gain K_p2	0~100	0~100	25
F2.04	ASR integral time K_i2	0.01~10.00s	0.01~10.00s	1.00s
F2.05	ASR switching point2	F2.02—F0.10	F2.02—F0.10	10.0Hz

F2.00-F2.05 are only valid for vector control and torque control and invalid for V/F control. Through F2.00-F2.05, user can set the proportional gain K_p and integral time K_i of speed regulator (ASR), so as to change the speed response characteristic. ASR's structure is shown in following figure.

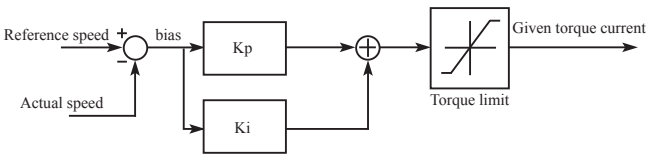

Figure 4-3 ASR diagram

F2.00 and F2.01 only take effect when output frequency is less than F2.02. F2.03 and F2.04 only take effect when output frequency is greater than F2.05. When output frequency is between F2.02 and F2.05, K_p and K_i are proportional to the bias between F2.02 and F2.05. For details, please refer to following figure.

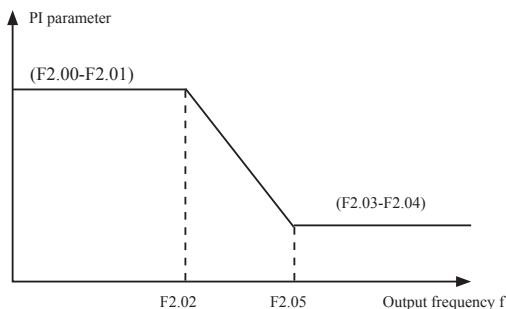

Figure 4.4 PI parameter diagram.

The system's dynamic response can be faster if the proportion gain K_p is increased; However, if K_p is too large, the system tends to oscillate.

The system dynamic response can be faster if the integral time K_i is decreased; However, if K_i is too small, the system becomes overshoot and tends to oscillate.

F2.00 and F2.01 are corresponding to K_p and K_i at low frequency, while F2.03 and F2.04 are corresponding to K_p and K_i at high frequency. Please adjust these parameters according to actual situation. The adjustment procedure is as follow:

- Increase the proportional gain (K_p) as far as possible without creating oscillation.
- Reduce the integral time (K_i) as far as possible without creating oscillation.

Function Code	Name	Description	Setting Range	Factory setting
F2.06	Slip ompensation rate of VC	50.0%~200.0%	50.0%~200.0%	100%

The parameter is used to adjust the slip frequency of vector control and improve the precision of speed control. Properly adjust this parameter can effectively restrain the static speed bias.

Function Code	Name	Description	Setting Range	Factory setting
F2.07	Torque upper limit	0.0~200.0%	0.0~200.0%	Depend on Mode

Notice:

- **100% setting corresponding to rated current. G model : 150.0%; P model. 120.0%.**
- **Under torque control, F2.07 and F2.09 are all related with torque setting.**

Function Code	Name	Description	Setting Range	Factory setting
F2.08	Torque setting source	0:Keypad(F2.09); 1:FIV; 2:FIC; 3:X8; 4:Multi-stepspeed; 5: Communication	0--5	0

0: Keypad (F2.09)

1:FIV

2:FIC

3:X8

4:Multi-step speed

5:Communication

1~5: Torque control is valid, which defines the torque setting source.

When the torque setting is minus, the motor will reverse.

Under speed control model, output torque matches load torque automatically, but limited by F2.07.

Under torque control model, output torque is limited by upper and lower frequency limit.

Notice:

- **speed control and torque control can be switched by using multi-function input terminals.**
- **1~5:100% corresponding to twice of rated current of inverter.**
- **When inverter decelerate to stop, Torque control model is switched to speed control mode automatically.**

Function Code	Name	Description	Setting Range	Factory setting
F2.09	Keypad torqueSetting	-200.0%~200.0%	-200.0%~200.0%	50.0%
F2.10	Upper frequency setting source	0:Keypad(F0.11); 1:FIV; 2:FIC; 3:X8; 4:Multi-step speed; 5: Communication	0-5	0

Notice:

- 1~4 100% Corresponding to maximum frequency.

4-4F3 Group: V/F Control

Function Code	Name	Description	Setting Range	Factory setting
F3.00	V/F curve selection	0:Linear curve 1: User-defined curve 2:Torque_stepdown curve (1.3 order) 3:Torque_stepdown curve (1.7 order) 4:Torque_stepdown	0-4	0

0: Linear V/F curve. It is applicable for normal constant torque load.

1: User-defined curve. It can be defined through setting (F3.03~F3.08).

2~4: Torque_stepdown curve. It is applicable for variable torque load, such as blower, pump and so on. Please refer to following figure.

Notice:

- V_b = Motor rated voltage f_b = Motor rated frequency.

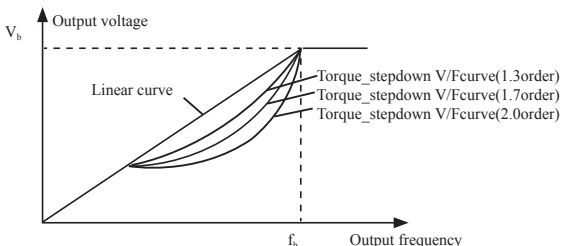

Figure 4.5V/F curve

Function Code	Name	Description	Setting Range	Factory setting
F3.01	Torque boost	0.0%: (auto) 0.1%~10.0%	0.1% ~10.0%	00.0%
F3.02	Torqueboostcut-off	0.0%~50.0%(motor rated frequency)	0.0%~50.0% (motor rated frequency)	20.0%

Torque boost will take effect when output frequency is less than cut-off frequency of torque boost (F3.02). Torque boost can improve the torque performance of V/F control at low speed.

The value of torque boost should be determined by the load. The heavier the load, the larger the value.

Notice:

• **This value should not be too large, otherwise the motor would be over-heat or the inverter would be tripped by over-current or over-load.**

If F3.01 is set to be 0, the inverter will boost the output torque according to the load automatically. Please refer to following diagram.

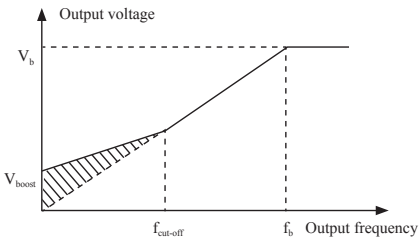

Figure 4.6. Torque boost by hand.

Function Code	Name	Description	Setting Range	Factory setting
F3.03	V/F frequency 1	0.00Hz~ F3.05	0.00Hz~ F3.05	0.00Hz
F3.04	V/F voltage 1	0.0%~100.0%	0.0%~100.0%	0.00Hz
F3.05	V/F frequency 2	F3.03~ F3.07	F3.03~ F3.07	30.00Hz
F3.06	V/F voltage 2	0.0%~100.0%	0.0%~100.0%	0.00Hz
F3.07	V/F frequency 3	F3.05~ F1.01	F3.05~ F1.01	
F3.08	V/F voltage 3	0.0%~100.0%	0.0%~100.0%	0.00Hz

This function is only active when F3.00 is set to be 1. F3.03~F3.08 are used to set the user-defined V/F curve. The value should be set according to the load characteristic of motor.

Notice:

- $0 < V1 < V2 < V3 < \text{rated voltage}$.
- $0 < f1 < f2 < f3 < \text{rated frequency}$.
- The voltage corresponding to low frequency should not be set too high, otherwise it may cause motor overheat or inverter fault.

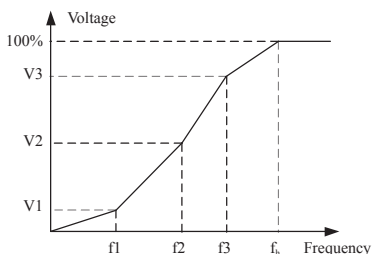

Figure 4.7 V/F curve setting diagram.

Function Code	Name	Description	Setting Range	Factory setting
F3.09	Slip compensation limit	0.00~200.0%	0.00~200.0%	0.0%

The slip compensation function calculates the torque of motor according to the output current and compensates for output frequency. This function is used to improve speed accuracy when operating with a load. F3.09 sets the slip compensation limit as a percentage of motor rated slip, the slip compensation limit is calculated as the formula: $F3.09 = f_b - n \cdot p / 60$

Fb= Motor rated frequency (F1.01)

N= Motor rated speed (F1.02) P= Pair of Motor poles

Function Code	Name	Description	Setting Range	Factory setting
F3.10	Auto energy saving selection	0: Disabled 1: Enabled	0-1	0

When F3.10 is set to be 1, while there is a light load such as pumps or fans, it will reduce the inverter output voltage and save energy.

Function Code	Name	Description	Setting Range	Factory setting
F3.11	Low-frequency threshold of restraining oscillation	0~10	0~10	2
F3.12	High-frequency threshold of restraining oscillation	0~10	0~10	0
F3.13	Boundary of restraining oscillation	0.0~F0.10	0.0~F0.10	30Hz

F3.11~F3.12 are only valid in the V/F control mode, When set F3.11 and F3.12 to be 0, the restraining oscillation is invalid. While set the values to be 1~3 will have the effect of restraining oscillation. When the running frequency is lower than F3.13, F3.11 is valid, when the running frequency higher than F3.13, F3.12 is valid.

4-5 F4 Group: Input Terminals

Function Code	Name	Description	Setting Range	Factory setting
F4.00	X1 Terminal function	0--39	0--39	1
F4.01	X2 Terminal function	0--39	0--39	4
F4.02	X3 Terminal function	0--39	0--39	7
F4.03	X4 Terminal function	0--39	0--39	0
F4.04	X5 Terminal function	0--39	0--39	0
F4.05	X6 Terminal function	0--39	0--39	0
F4.06	X7 Terminal function	0--39	0--39	0
F4.07	X8 terminal function	0--39	0--39	0

The meaning of each setting is shown in following table

Setting value	Function	Description
0	Invalid	Please set unused terminals to be invalid to avoid malfunction
1	Forward	Please refer to description of F4.10.
2	Reverse	
3	3-wire control	Please refer to description of F4.10.
4	Jog forward	Please refer to description of F8.00~F8.02.
5	Jog reverse	

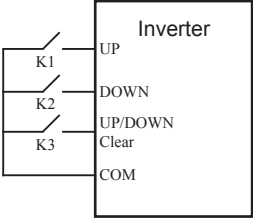
Setting value	Function	Description																				
6	Coast to stop	The inverter blocks the output immediately. The motor coasts to stop by its mechanical inertia.																				
7	Reset fault	Resets faults that have occurred. It has the same function as STOP/RST																				
8	Pause running	When this terminal takes effect, inverter decelerates to stop and save current status, such as PLC, traverse frequency and PID. When this terminal takes no effect, inverter restores the status																				
9	External fault input	Stop the inverter and output an alarm when a fault occurs in a peripheral device.																				
10	Up command	<p>The reference frequency of inverter can be adjusted by UP command and DOWN command.</p>  <p>Use this terminal to clear UP/DOWN setting. Please refer to description of F0.09</p>																				
11	DOWN command																					
12	Clear UP/DOWN																					
13	Switch between X and Y	<table border="1" data-bbox="480 1146 909 1333"> <thead> <tr> <th>F0.03</th> <th>X</th> <th>y</th> <th>X+Y</th> </tr> </thead> <tbody> <tr> <th>Terminal action</th> <td></td> <td></td> <td></td> </tr> <tr> <td>13 valid</td> <td>Y</td> <td>X</td> <td></td> </tr> <tr> <td>14 valid</td> <td>X+Y</td> <td></td> <td>X</td> </tr> <tr> <td>15 valid</td> <td></td> <td>X+Y</td> <td>Y</td> </tr> </tbody> </table>	F0.03	X	y	X+Y	Terminal action				13 valid	Y	X		14 valid	X+Y		X	15 valid		X+Y	Y
F0.03	X		y	X+Y																		
Terminal action																						
13 valid	Y	X																				
14 valid	X+Y		X																			
15 valid		X+Y	Y																			
14	Switch between X and X+Y																					
15	Switch between Y and X+Y																					

Setting value	Function	Description															
16	Multi-step speed reference 1	16 steps speed control can be realized by the combination of these four terminals. For details, please refer to: Multi-step speed reference terminal status and according step value table:															
17	Multi-step speed reference 2																
18	Multi-step speed reference 3																
19	Multi-step speed reference 4																
20	Multi-step speed pause	Keep current step unchanged no matter what the input status of four multi-step speed terminals is.															
21	ACC/DEC time selection 1	4 groups of ACC/DEC time can be selected by the combination of these two terminals.															
22	ACC/DEC time selection 2	<table border="1"> <thead> <tr> <th>ACC/DEC time selection 2</th> <th>ACC/DEC time selection 1</th> <th>ACC/DEC time</th> </tr> </thead> <tbody> <tr> <td>OFF</td> <td>OFF</td> <td>ACC/DEC time 1 (F0.07, F0.08)</td> </tr> <tr> <td>OFF</td> <td>ON</td> <td>ACC/DEC time 2 (F8.03, F8.04)</td> </tr> <tr> <td>ON</td> <td>OFF</td> <td>ACC/DEC time 3 (F8.05, F8.06)</td> </tr> <tr> <td>ON</td> <td>ON</td> <td>ACC/DEC time 4 (F8.07, F8.08)</td> </tr> </tbody> </table>	ACC/DEC time selection 2	ACC/DEC time selection 1	ACC/DEC time	OFF	OFF	ACC/DEC time 1 (F0.07, F0.08)	OFF	ON	ACC/DEC time 2 (F8.03, F8.04)	ON	OFF	ACC/DEC time 3 (F8.05, F8.06)	ON	ON	ACC/DEC time 4 (F8.07, F8.08)
		ACC/DEC time selection 2	ACC/DEC time selection 1	ACC/DEC time													
		OFF	OFF	ACC/DEC time 1 (F0.07, F0.08)													
		OFF	ON	ACC/DEC time 2 (F8.03, F8.04)													
ON	OFF	ACC/DEC time 3 (F8.05, F8.06)															
ON	ON	ACC/DEC time 4 (F8.07, F8.08)															
23	Reset simple PLC when stop	When simple PLC stops, the status of PLC such as running step, running time and running frequency will be cleared when this terminal is enabled.															
24	Pause simple PLC	Inverter runs at zero frequency and PLC pauses the timing when this terminal is enabled. If this terminal is disabled, inverter will start and continue the PLC operation from the status before pause.															
25	Pause PID	PID adjustment will be paused and inverter keeps output frequency unchanged.															

Setting value	Function	Description
26	Pause traverse operation	Inverter keeps output frequency unchanged. If this terminal is disabled, inverter will continue traverse operation with current frequency.
27	Reset traverse operation	Reference frequency of inverter will be forced as center frequency of traverse operation.
28	Reset counter	Clear the value of counter.
29	Forbid torque	Torque control is forbidden and switch inverter to run in control mode speed control mode.
30	Forbid the function of ACC/DEC	ACC/DEC is invalid and maintains output frequency if it is enabled.
31	Counter input	The pulse input terminal of internal counter. Maximum pulse frequency: 200Hz
32	UP/DOWN invalid temporarily	UP/DOWN setting is invalid but will not be cleared. When this terminal is disabled, UP/DOWN value before will be valid again.
33~39	Reserved	

Multi-step speed reference terminal status and according step value table:

Terminal Step	Multi-step speed reference 1	Multi-step speed reference 2	Multi-step speed reference 3	Multi-step speed reference 4
0	OFF	OFF	OFF	OFF
1	ON	OFF	OFF	OFF
2	OFF	ON	OFF	OFF
3	ON	ON	OFF	OFF
4	OFF	OFF	ON	OFF
5	ON	OFF	ON	OFF
6	OFF	ON	ON	OFF
7	ON	ON	ON	OFF
8	OFF	OFF	OFF	ON
9	ON	OFF	OFF	ON
10	OFF	ON	OFF	ON
11	ON	ON	OFF	ON
12	OFF	OFF	ON	ON
13	ON	OFF	ON	ON
14	OFF	ON	ON	ON
15	ON	ON	ON	ON

Function Code	Name	Description	Setting Range	Factory setting
F4.08	X8 selection	0: High speed pulse input 1: ON-OFF input	0~1	0
F4.09	ON-OFF filter times	1~10	1~10	5
F4.10	FW D/REV control mode	0: 2-wire control mode 1 1: 2-wire control mode 2 2: 3-wire control mode 1 3: 3-wire control mode 2	0~3	0

This parameter defines four different control modes that control the inverter operation through external terminals.

0: 2-wire control mode 1: Integrate START/STOP command with run direction.

K1	K2	Run command
OFF	OFF	Stop
ON	OFF	FWD
OFF	ON	REV
ON	ON	Maintenance

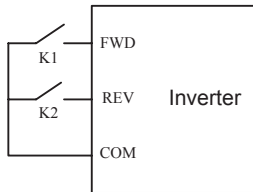

Figure 6.11 2-wire control mode 1

1: 2-wire control mode 2: START/STOP command is determined by FWD terminal Run direction is determined by REV terminal.

K1	K2	Run command
OFF	OFF	Stop
ON	OFF	FWD
OFF	ON	Stop
ON	ON	REV

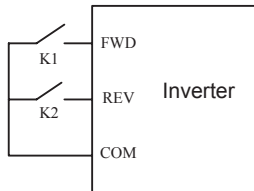

Figure 6.12 2-wire control mode 2

2: 3-wire control mode 1:

PB1: Start button

PB2: Stop button

K: Run direction button

Terminal Xin is the multifunctional input terminal of X1~X4 and X8.

The terminal function should be set to be 3(3-wire control)

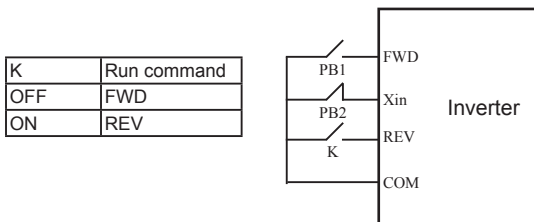

Figure 6.13 3-wire control mode 1

3: 3-wire control mode 2:

PB1: Forward run button

PB2: Stop button (NC)

K: Reverse run button

Terminal Xin is the multifunctional input terminal of X1~X4 and X8.

The terminal function should be set to be 3(3-wire control)

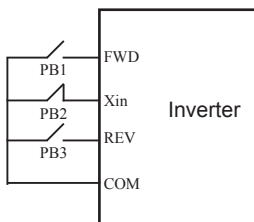

Figure 6.14 3-wire control mode 2

Notice:

- When 2-wire control mode is active, the inverter will not run in following situation even if FWD/REV terminal is enabled.
- Coast stop (press RUN and STOP/RST at the same time).
- Stop command from serial communication.
- FWD/REV terminal is enabled before power on.

Function Code	Name	Description	Setting Range	Factory setting
F4.11	UP/DOWN setting change rate	0.01~50.00Hz/s	0.01~50.00Hz/s	0.50Hz/s
F4.12	FIV lower limit	-10V~10.00V	-10V~10.00V	0.00V
F4.13	FIV lower limit corresponding setting	-100.0%~100.0%	-100.0%~100.0%	0.0%
F4.14	FIV upper limit	0.00V~10.00V	0.00V~10.00V	10.00V
F4.15	FIV upper limit corresponding setting	-100.0%~100.0%	-100.0%~100.0%	100.0%
F4.16	FIV filter time constant	0.00s~10.00s	0.00s~10.00s	0.10s

These parameters determine the relationship between analog input voltage and the corresponding setting value. When the analog input voltage exceeds the range between lower limit and upper limit, it will be regarded as the upper limit or lower limit.

The analog input FIV can only provide voltage input, and the range is -10V~10V.

For different applications, the corresponding value of 100.0% analog setting is different. For details, please refer to description of each application.

Notice: FIV lower limit must be less or equal to FIV upper limit.

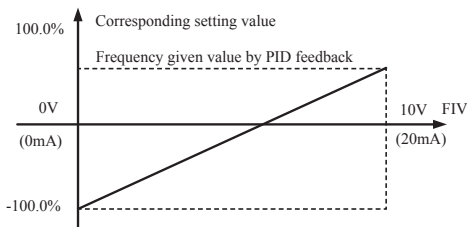

Figure 4.12 Relationship between AI and corresponding setting. FIV filter time constant is effective when there are sudden changes or noise in the analog.

Function Code	Name	Description	Setting Range	Factory setting
F4.17	FIC lower limit	0.00V~10.00V	0.00V~10.00V	0.00V
F4.18	FIC lower limit corresponding setting	-100.0%~100.0%	-100.0%~100.0%	0.0%
F4.19	FIC upper limit	0.00V~10.00V	0.00V~10.00V	10.00V
F4.20	FIC upper limit corresponding setting	-100.0%~100.0%	-100.0%~100.0%	100.0%
F4.21	FIC filter time constant	0.00s~10.00s	0.00s~10.00s	0.10s

Please refer to description of FIV. When FIC is set as 0~20mA current input, the corresponding voltage range is 0~5V.

Function Code	Name	Description	Setting Range	Factory setting
F4.22	X8 lower limit	0.0 kHz ~50.0kHz	0.0 kHz ~50.0kHz	0.0KHz
F4.23	X8 lower limit corresponding setting	-100.0%~100.0%	-100.0%~100.0%	0.0%
F4.24	X8 upper limit	0.0 kHz ~50.0kHz	0.0 kHz ~50.0kHz	50.0KHz
F4.25	X8 upper limit corresponding setting	-100.0%~100.0%	-100.0%~100.0%	100.0%
F4.26	X8filter time constant	0.00s~10.00s	0.00s~10.00s	0.10s

The description of F4.22-F4.26 is similar to FIV.

4-6 F5 Group: Output Terminals

Function Code	Name	Description	Setting Range	Factory setting
F5.00 (Optional)	Relay RA, RB, RC output selection	0--20	0--20	4
F5.01	Relay YA, YB, YC output selection	0--20	0--20	0
F5.02	YO ON-OFF Output selection	0--20	0--20	1

YO/Relay output functions are indicated in the following table:

Setting Value	Function	Description
0	No output	Output terminal has no function
1	Running	ON: Run command is ON or voltage is being output
2	Run forward	ON: During forward run.
3	Run reverse	ON: During reverse run.
4	Fault output	ON: Inverter is in fault status.
5	FDT reached	Please refer to description of F8.21, F8.22.
6	Frequency reached	Please refer to description of F8.23.
7	Zero speed running	ON: The running frequency of inverter and setting frequency are zero.
8	Preset count value reached	Please refer to description of F8.18.
9	Specified count value reached	Please refer to description of F8.19.
10	overload pre-warming of inverter	Please refer to description of Fb.04~Fb.06
11	Simple PLC step completed	After simple PLC completes one step, inverter will output ON signal for 500ms
12	PLC cycle completed	After simple PLC completes one cycle, inverter will output ON signal for 500ms
13	Running time reached	ON: The accumulated running time of inverter reaches the value of F 8.20
14	Upper frequency limit reached	ON: Running frequency reaches the value of F 0.11
15	Lower frequency limit reached	ON: Running frequency reaches the value of F 0.12
16	Ready	ON: Inverter is ready (no fault, power is ON)
17~20	Reserved	Reserved

Function Code	Name	Description	Setting Range	Factory setting
F5.03	YO selection	0: High-speed pulse output 1: ON-OFF output	0--1	0

0: High-speed pulse output: The maximum pulse frequency is 50.0 kHz. Please refer to description of F5.02.

Function Code	Name	Description	Setting Range	Factory setting
F5.04	FOV function selection	0--10	0--10	4
F5.05	FOC function selection	0--10	0--10	0
F5.06	YO function selection	0--10	0--10	1

FOV/FOC/YO output functions are indicated in the following table:

Setting Value	Function	Range
0	Output frequency	0~maximum frequency(F0.10)
1	Reference frequency	0~maximum frequency(F0.10)
2	Running speed	0~2* rated synchronous speed of motor
3	Output current	0~2* inverter rated current
4	Output voltage	0~1.5* inverter rated voltage
5	Output power	0~2* rated power
6	Setting torque	0~2* rated current of motor
7	Output torque	0~2* rated current of motor
8	FIV voltage	-10~10V
9	FIC	0--10V/0--20mA
10	X8	0.1--50.00kHz

Function Code	Name	Description	Setting Range	Factory setting
F5.07	FOV lower limit	00.0%~100.0%	00.0%~100.0%	0.0%
F5.08	FOV lower limit corresponding output	0.00V~10.00V	0.00V~10.00V	0.0V

Function Code	Name	Description	Setting Range	Factory setting
F5.09	FOV upper limit	00.0%~100.0%	00.0%~100.0%	100.0%
F5.10	FOV upper limit corresponding output	0.00V~10.00V	0.00V~10.00V	10.0V

These parameters determine the relationship between analog output voltage/current and the corresponding output value. When the analog output value exceeds the range between lower limit and upper limit, it will output the upper limit or lower limit.

When FOV is current output, 1mA is corresponding to 0.5V.

For different applications, the corresponding value of 100.0% analog output is different. For details, please refer to description of each application.

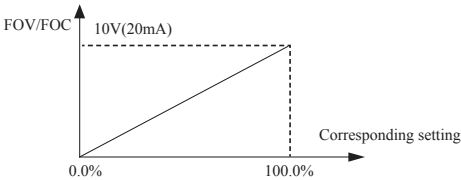

Figure 4.13 Relationship between FOV/FOC and corresponding setting.

Function Code	Name	Description	Setting Range	Factory setting
F5.11	FOC lower limit	00.0%~100.0%	00.0%~100.0%	0.0%
F5.12	FOC lower limit corresponding output	0.00V~10.00V	0.00V~10.00V	0.0V
F5.13	FOC upper limit	00.0%~100.0%	00.0%~100.0%	100.0%
F5.14	FOC upper limit corresponding output	0.00V~10.00V	0.00V~10.00V	10.0V
F5.15	YO lower limit	00.0%~100.0%	00.0%~100.0%	0.0%
F5.16	YO lower limit corresponding output	0.00~50.0kHz	0.00~50.0kHz	0.0kHz
F5.17	YO upper limit	00.0%~100.0%	00.0%~100.0%	100.0%

Function Code	Name	Description	Setting Range	Factory setting
F5.18	YO upper limit corresponding output	0.00~50.0kHz	0.00~50.0kHz	50.0kHz

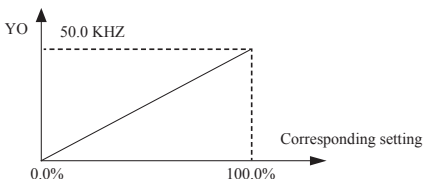

Figure 4.14 Relationship between YO and corresponding setting.

4-7 F6 Group: Start and Stop Control

Function Code	Name	Description	Setting Range	Factory setting
F6.00	Acceleration / Deceleration mode	0: Linear 1: reserved	0-1	0

0: Linear: Output frequency will increase or decrease with fixed acceleration or deceleration time.

1: Reserved

Notice:

• The inverter offers 4 groups of specific acceleration and deceleration.

Function Code	Name	Description	Setting Range	Factory setting
F6.01	Start Mode	0: Start directly 1: DC braking and start 2: Speed tracking and start	0-2	0

0: Start directly: Start the motor at the starting frequency determined by F6.02.

1: DC braking and start: Inverter will output DC current firstly and then start the motor at the starting frequency. Please refer to description of F6.04 and F6.05. It is suitable for the motor which have small inertia load and may reverse rotation when start.

2: Speed tracking and start: Inverter detects the rotation speed and direction of motor, then start running to its reference frequency based on current speed. This can realize smooth start of rotating motor with big inertia load when instantaneous power off.

Notice:

- It only applies on the inverter of 7.5kW and above.

Function Code	Name	Description	Setting Range	Factory setting
F6.02	Starting frequency	0.00~10.00Hz	0.00~10.00Hz	0.00Hz
F6.03	Hold time of starting frequency	0.0~50.0s	0.0~50.0s	0.0s

Notice:

- Set proper starting frequency can increase the starting torque.
- If the reference frequency is less than starting frequency, inverter will be at stand-by status. The indicator of RUN/TUNE lights on, inverter has no output.
- The starting frequency could be less than the lower frequency limit (F0.12).
- F6.02 and F6.03 take no effect during FWD/REV switching.

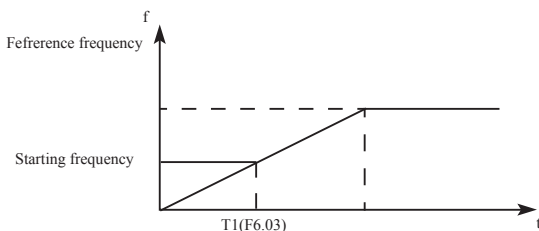

Figure 4.15 Starting diagram

Function Code	Name	Description	Setting Range	Factory setting
F6.04	DC Braking current before start	0.0~150.0%	0.0~150.0%	0.0%
F6.05	DC Braking time before start	0.0~50.0s	0.0~50.0s	0.0s

When inverter starts, it performs DC braking according to F6.04 firstly, then start to accelerate after F6.05.

Notice:

- **DC braking will take effect only when F6.01 is set to be 1.**
- **DC braking is invalid when F6.05 is set to be 0.**
- **The value of F6.04 is the percentage of rated current of inverter. The bigger the DC braking current, the greater the braking torque**

Function Code	Name	Description	Setting Range	Factory setting
F6.06	Stop mode	0: Deceleration to stop 1: Coast to stop	0-1	0

0: Linear: Output frequency will increase or decrease with fixed acceleration or deceleration time.

1: Coast to stop

Notice:

- **The inverter offers 4 groups of specific acceleration and deceleration time, which can be determined by the multifunctional ON-OFF input terminals (F4 Group).**

Function Code	Name	Description	Setting Range	Factory setting
F6.07	Starting frequency of DC braking	0.00~F0.10	0.00~F0.10	0.00Hz
F6.08	Waiting time before DC braking	0.0~50.0s	0.0~50.0s	0.0s
F6.09	DC braking current	0.0~150.0%	0.0~150.0%	0.0%
F6.10	DC braking time	0.0~50.0s	0.0~50.0s	0.0s

Starting frequency of DC braking: Start the DC braking when running frequency reaches starting frequency determined by F6.07.

Waiting time before DC braking: Inverter blocks the output before starting the DC braking. After this waiting time, the DC braking will be started so as to prevent over-current fault caused by DC braking at high speed.

DC braking current: The value of F6.09 is the percentage of rated current of inverter. The bigger the DC braking current is, the greater

the braking torque is. DC braking time: The time used to perform DC braking. If the time is 0, the DC braking will be invalid.

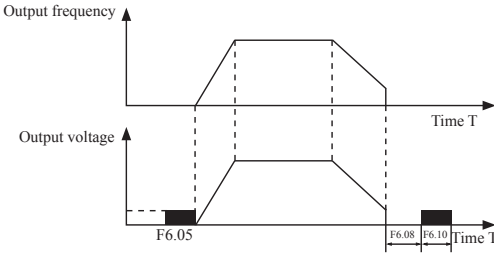

Figure 4.16 DC braking diagram

Function Code	Name	Description	Setting Range	Factory setting
F6.11	Dead time of FW D/REV	0.0~3600.0s	0.0~3600.0s	0.0s

Set the hold time at zero frequency in the transition between forward and reverse running. It is shown as following figure.

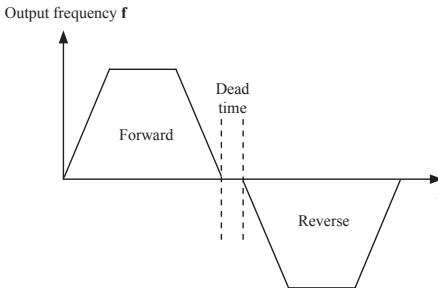

Figure 4.17 FW D/REV dead time diagram

Function Code	Name	Description	Setting Range	Factory setting
F6.12	Action when running frequency is less than the lower frequency limit	0:running at the lower frequency limit 1:stop 2:stand-by	0-2	0

0: Running at the lower frequency limit (F0.12): The inverter runs at F0.12 when the running frequency is less than F0.12

1: Stop: This parameter is used to prevent motor running at low speed for a long time.

2: Stand-by: Inverter will Coast to stop when the running frequency is less than F0.12 When the reference frequency is higher than or equal to F0.12 again, the inverter will start to run automatically.

Function Code	Name	Description	Setting Range	Factory setting
F6.13	Delay time for restart	0.0~3600.0s	0.0~3600.0s	0.0s
F6.14	Restart after power off	0: Disabled 1: Enabled	0-1	0

0: Disabled: Inverter will not automatically restart when power on again until run command takes effect.

1: Enabled: When inverter is running, after power off and power on again, if run command source is key control (F0.02=0) or communication control (F0.02=2), inverter will automatically restart after delay time determined by F6.14; if run command source is terminal control (F0.02=1), inverter will automatically restart after delay time determined by F6.14 only if FWD or REV is active.

Notice:

- If F6.14 is set to be 1, it is recommended that start mode should be set as speed tracing mode (F6.01=2).
- This function may cause the inverter restart automatically, please be cautious.

Function Code	Name	Description	Setting Range	Factory setting
F6.15	Waiting time of restart	0.0~3600.0s	0.0~3600.0s	0.0s
F6.16	Terminal function examined when power is on	0: Disabled 1: Enabled	0: Disabled 1: Enabled	0

Notice:

- This function only takes effect if run command source is terminal control.
- If F6.16 is set to be 0, when power on, inverter will not start even if FWD/REV terminal is active, until FWD/REV terminal disabled and enabled again.

- If F6.16 is set to be 1, when power on and FWD/REV terminal is active, inverter will start automatically.
- This function may cause the inverter restart automatically, please be cautious.

4-8 F7 Group: Display Interface

Function Code	Name	Description	Setting Range	Factory setting
F7.00	User password	0~65535	00~65535	0

The password protection function will be valid when F7.00 is set to be any nonzero data. When F7.00 is set to be 00000, user's password set before will be cleared and the password protection function will be disabled.

After the password has been set and becomes valid, the user can not access menu if the user's password is not correct. Only when a correct user's password is input, the user can see and modify the parameters. Please keep user's password in mind.

Function Code	Name	Description	Setting Range	Factory setting
F7.01	Reserve			
F7.02	Reserve			
F7.03	JOG function selection	0: Display status switching: 1: JOG; 2: FW D/REV switching 3: Clear UP/DOWN setting 4. QUICK set mode	0-4	0

JOG is a multifunctional key, whose function can be defined by the value.

0. Display status switching

1: Jog: Press JOG, the inverter will jog.

2: FW D/REV switching: Press JOG, the running direction of inverter will reverse.

It is only valid if F0.02 is set to be 0.

3: Clear UP/DOWN setting: Press JOG, the UP/DOWN setting will be cleared.

4. Quick debugging mode.

Function Code	Name	Description	Setting Range	Factory setting
F7.04	STOP/RST function selection	0: Valid when keypad control (F0.02=0) 1: Valid when keypad or terminal control (F0.02=0or1) 2: Valid when keypad or communication control (F0.02=0or2) 3: Always valid	0-2	0

Notice:

- The value of F7.04 only determines the STOP function of STOP/RST .
- The RESET function of STOP/RST is always valid.

Function Code	Name	Description	Setting Range	Factory setting
F7.05	Reserve			0
F7.06	Running status display selection1	0--0XFFFF	0--0XFFFF	0X07FF
F7.07	Running status display selection2	0--0XFFFF	0--0XFFFF	0X0000

F7.06 and F7.07 define the parameters that can be displayed by LED in running status. If Bit is 0, the parameter will not be displayed; If Bit is 1, the parameter will be displayed.

Press SHIFT to scroll through these parameters in right order .

Press DATA/ENT + JOG to scroll through these parameters in left order.

The display content corresponding to each bit of P7.06 is described in the following table:

BIT7	BIT6	BIT5	BIT4	BIT3	BIT2	BIT1	BIT0
Output power	Line speed	Rotation speed	Output current	Output voltage	DC bus voltage	Reference frequency	Running frequency
BIT15	BIT14	BIT13	BIT12	BIT11	BIT10	BIT9	BIT8
Step No. of PLC or multi-step	Count value	Torque setting value	Output terminal status	Input terminal status	PID feedback	PID preset	Output torque

For example, if user wants to display output voltage, DC bus voltage, Reference frequency, Output frequency, Output terminal status, the value of each bit is as the following table.

BIT7	BIT6	BIT5	BIT4	BIT3	BIT2	BIT1	BIT0
0	0	0	0	1	1	1	1
BIT15	BIT14	BIT13	BIT12	BIT11	BIT10	BIT9	BIT8
0	0	0	1	0	0	0	0

The value of F7.06 is 100Fh.

Notice:

- I/O terminal status is displayed in decimal.

For details, please refer to description to each bit of F7.07 is described in the following table:

BIT7	BIT6	BIT5	BIT4	BIT3	BIT2	BIT1	BIT0
Reserver	Reserver	0	Load percentage of inverter	Load percentage of motor	X8 frequency	FIC	FIV
BIT15	BIT14	BIT13	BIT12	BIT11	BIT10	BIT9	BIT8
Reserver	Reserver	Reserver	Reserver	Reserver	Reserver	Reserver	Reserver

Function Code	Name	Description	Setting Range	Factory setting
F7.08	Stop status display selection	0—0XFFFF	0—0XFFFF	0X00F

F7.08 determines the display parameters in stop status. The setting method is similar with F7.06.

The display content corresponding to each bit of F7.08 is described in the following table:

BIT7	BIT6	BIT5	BIT4	BIT3	BIT2	BIT1	BIT0
FIC	FIV	PID feedback	PID preset	Output terminal status	Input terminal status	DC bus voltage	Reference frequency
BIT15	BIT14	BIT13	BIT12	BIT11	BIT10	BIT9	BIT8
Reserver	Reserver	Reserver	Reserver	Reserver	Reserver	Reserver	X8 frequency

Function Code	Name	Description	Setting Range	Factory setting
F7.09	Coefficient of rotatio speed	0.1~999.9% Actual mechanical speed = 120 * output frequency *F7.09 / Number of poles of motor	0.1~999.9%	100.0%

This parameter is used to calibrate the bias between actual mechanical speed and rotation speed. The formula is as below:
 Actual mechanical speed = 120 * output frequency * F7.09 / Number of poles of motor.

Function Code	Name	Description	Setting Range	Factory setting
F7.10	Coefficient of line speed	0.1~999.9% Line speed = actual mechanical speed * F7.10	0.1~999.9%	1.0%

This parameter is used to calculate the line speed based on actual mechanical speed. The formula is as below:
 Line speed = actual mechanical speed * F7.10

Function Code	Name	Description	Setting Range	Factory setting
F7.11	Temperature Rectify module	0~100.0°C	0~100.0°C	
F7.12	Temperature IGBT module	0~100.0°C	0~100.0°C	
F7.13	Software version			
F7.14	Inverter rated power	0-3000KW	0-3000KW	Depend on Mode

Function Code	Name	Description	Setting Range	Factory setting
F7.15	Inverter rated current	0.0-6000A	0.0-6000A	Depend on Mode
F7.16	Accumulated running time	0~65535h	0~65535h	

rectify module temperature: Indicates the temperature of rectify module. Overheat protection point of different model may be different.

IGBT module temperature: Indicates the temperature of IGBT module. Overheat protection point of different model may be different.

Software version: Indicates current software version of DSP.

Accumulated running time: Displays accumulated running time of inverter.

Notice:

- Above parameters are read only.

Function Code	Name	Description	Setting Range	Factory setting
F7.17	Third latest fault type	0-25		
F7.18	Second latest fault type	0-25		
F7.19	Latest fault type	0-25		

These parameters record three recent fault types. For details, please refer to description of chapter 5.

Function Code	Name	Description	Setting Range	Factory setting
F7.20	Output frequency at current fault			
F7.21	Output current at current fault			
F7.22	DC bus voltage at current fault			

F7.23	Input terminal status at current fault	<p>This value records ON-OFF input terminal status at current fault. The meaning of each bit is as below:</p> <table border="1" data-bbox="474 304 902 440"> <tr> <td>BIT7</td> <td>BIT6</td> <td>BIT6</td> <td>BIT6</td> </tr> <tr> <td>X8</td> <td>X7</td> <td>X6</td> <td>X5</td> </tr> <tr> <td>BIT7</td> <td>BIT6</td> <td>BIT6</td> <td>BIT6</td> </tr> <tr> <td>X4</td> <td>X3</td> <td>X2</td> <td>X1</td> </tr> </table> <p>1 indicates corresponding input terminal is ON, while 0 indicates OFF. Notice: This value is displayed as decimal.</p>	BIT7	BIT6	BIT6	BIT6	X8	X7	X6	X5	BIT7	BIT6	BIT6	BIT6	X4	X3	X2	X1
BIT7	BIT6	BIT6	BIT6															
X8	X7	X6	X5															
BIT7	BIT6	BIT6	BIT6															
X4	X3	X2	X1															
F7.24	Output terminal status at current fault	<p>This value records output terminal status at current fault. The meaning of each bit is as below:</p> <table border="1" data-bbox="474 748 902 816"> <tr> <td>BIT3</td> <td>BIT2</td> <td>BIT1</td> <td>BIT0</td> </tr> <tr> <td>Reserved</td> <td>R02</td> <td>R01</td> <td>Y0</td> </tr> </table> <p>1 indicates corresponding output terminal is ON, while 0 indicates OFF. Notice: This value is displayed as decimal.</p>	BIT3	BIT2	BIT1	BIT0	Reserved	R02	R01	Y0								
BIT3	BIT2	BIT1	BIT0															
Reserved	R02	R01	Y0															

4-9 F8 Group: Enhanced Function

Function Code	Name	Description	Setting Range	Factory setting
F8.00	Jog reference	0.00~F0.10	0.00~F0.10	5.00hz
F8.01	Jog acceleration time	0.1~3600.0s	0.1~3600.0s	Depend on Mode
F8.02	Jog deceleration time	0.1~3600.0s	0.1~3600.0s	Depend on Mode
F8.03	Acceleration time 2	0.1~3600.0s	0.1~3600.0s	Depend on Mode
F8.04	Deceleration time2	0.1~3600.0s	0.1~3600.0s	Depend on Mode
F8.05	Acceleration time 3	0.1~3600.0s	0.1~3600.0s	Depend on Mode

Function Code	Name	Description	Setting Range	Factory setting
F8.06	Deceleration time3	0.1~3600.0s	0.1~3600.0s	Depend on Mode
F8.07	Acceleration time 4	0.1~3600.0s	0.1~3600.0s	Depend on Mode
F8.08	Deceleration time4	0.1~3600.0s	0.1~3600.0s	Depend on Mode

For details, please refer to description of F0.07 and F0.08

Function Code	Name	Description	Setting Range	Factory setting
F8.09	Skip Frequency 1	0.00~F0.10	0.00~F0.10	0.00hz
F8.10	Skip Frequency 2	0.00~F0.10	0.00~F0.10	0.00hz
F8.11	Skip Frequency bandwidth	0.00~F0.10	0.00~F0.10	0.00hz

By means of setting skip frequency, the inverter can keep away from the mechanical resonance with the load. F8.09 and F8.10 are centre value of frequency to be skipped.

Notice:

- If F8.11 is 0, the skip function is invalid.
- If both F8.09 and F8.10 are 0, the skip function is invalid no matter what F8.11 is.
- Operation is prohibited within the skip frequency bandwidth, but changes during acceleration and deceleration are smooth without skip.

The relation between output frequency and reference frequency is shown in following figure.

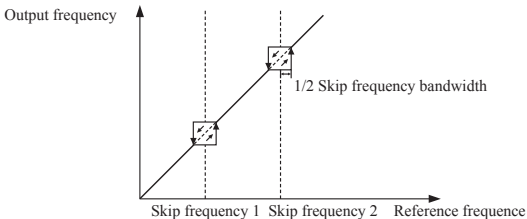

Figure 4.18 Skip frequency diagram

Function Code	Name	Description	Setting Range	Factory setting
F8.12	Traverse amplitude	0.0~100.0%	0.0~100.0%	0.0%
F8.13	Jitter frequency	0.0~50.0%	0.0~50.0%	0.0%
F8.14	Rise time of traverse	0.1~3600.0s	0.1~3600.0s	5.0s
F8.15	Fall time of traverse	0.1~3600.0s	0.1~3600.0s	5.0s

Traverse operation is widely used in textile and chemical fiber industry. The typical application is shown in following figure.

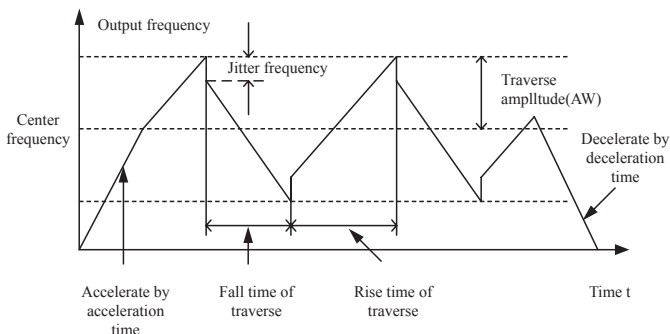

Figure 4.19 Traverse operation diagram

Center frequency (CF) is reference frequency.

Traverse amplitude (AW) = center frequency (CF) * F8.12%
 Jitter frequency = traverse amplitude (AW) * F8.13%

Rise time of traverse: Indicates the time rising from the lowest traverse frequency to the highest traverse frequency.

Fall time of traverse: Indicates the time falling from the highest traverse frequency to the lowest traverse frequency.

Notice:

- **F8.12 determines the output frequency range which is as below: $(1-F8.12\%) \text{reference frequency} \leq \text{output frequency} \leq (1+F8.12\%) * \text{reference frequenc.}$**

Function Code	Name	Description	Setting Range	Factory setting
F8.16	Auto reset times	0~3	0~3	0

Function Code	Name	Description	Setting Range	Factory setting
F8.17	Reset interval	0.1~100.0s	0.1~100.0s	1.0s

Auto reset function can reset the fault in preset times and interval. When F8.16 is set to be 0, it means “auto reset” is disabled and the protective device will be activated in case of fault.

Notice:

- The fault such as UC 1, UC 2, UC 3, OH1 and OH2 cannot be reset automatically.

Function Code	Name	Description	Setting Range	Factory setting
F8.18	Preset count value	F8.19~65535	F8.19~65535	0
F8.19	Specified count value	0~F8.18	0~F8.18	0

The count pulse input channel can be X1~X4 ($\leq 200\text{Hz}$) and X8.

If function of output terminal is set as preset count reached, when the count value reaches preset count value (F8.18), it will output an ON-OFF signal. Inverter will clear the counter and restart counting. If function of output terminal is set as specified count reached, when the count value reaches specified count value (F8.19), it will output an ON-OFF signal until the count value reaches preset count value (F8.18). Inverter will clear the counter and restart counting.

Notice:

- Specified count value (F8.19) should not be greater than preset count value (P8.18).
- Output terminal can be RA/B/C, YA/B/C or YO.

This function is shown as following figure.

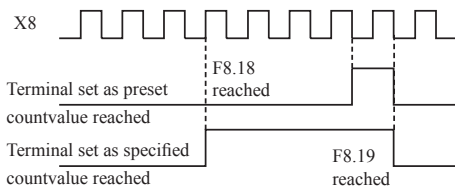

Figure 4.20 Timing chart for preset and specified count reached

Function Code	Name	Description	Setting Range	Factory setting
F8.20	Preset running time	0~65535h	0~65535h	65535h

If function of output terminal is set as running time reached, when the accumulated running time reaches the preset running time, it will output an ON-OFF signal

Function Code	Name	Description	Setting Range	Factory setting
F8.21	FDT level	0.00~ F0.10	0.00~ F0.10	50.00Hz
F8.22	FDT lag	0.0~100.0%	0.0~100.0%	5.0%

When the output frequency reaches a certain preset frequency (FDT level), output terminal will output an ON-OFF signal until output frequency drops below a certain frequency of FDT level (FDT level - FDT lag), as shown in following figure.

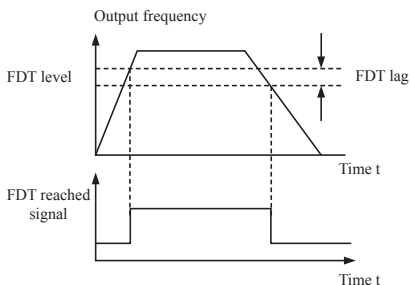

Figure 4.21 FDT level and lag diagram

Function Code	Name	Description	Setting Range	Factory setting
F8.23	Frequency arrive detecting range	0.0~100.0%(maximum frequency)	0.0%	50.00Hz

When output frequency is within the detecting range of reference frequency, an ON-OFF signal will be output. The function can adjust the detecting range.

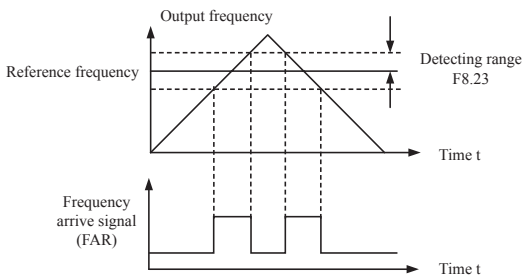

Figure 4.22 Frequency arriving detection diagram

Function Code	Name	Description	Setting Range	Factory setting
F8.24	Droop control	0.00~10.00Hz	0.00~10.00Hz	0.00Hz

When several motors drive the same load, each motor's load is different because of the difference of motor's rated speed. The load of different motors can be balanced through droop control function which makes the speed droop along with load increase. When the motor outputs rated torque, actual frequency drop is equal to F8.24. User can adjust this parameter from small to big gradually during commissioning. The relation between load and output frequency is in the following figure.

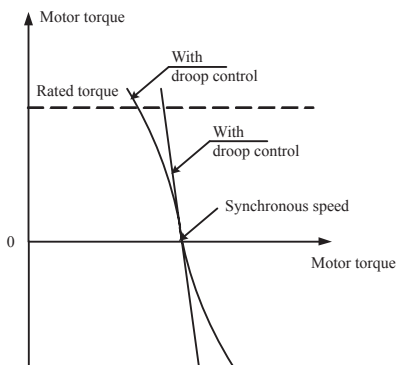

Figure 4.23 Droop control diagram

Function Code	Name	Description	Setting Range	Factory setting
F8.25	Brake threshold voltage	115.0~140.0%	115.0~140.0%	Depend on Mode

When the DC bus voltage is greater than the value of F8.25, the inverter will start dynamic braking.

Notice:

- **Factory setting is 120% if rated voltage of inverter is 220V.**
- **Factory setting is 130% if rated voltage of inverter is 380V.**
- **The value of F8.25 is corresponding to the DC bus voltage at rated input voltage.**

Function Code	Name	Description	Setting Range	Factory setting
F8.26	Cooling fan control	0: Auto stop mode 1: Always working	0-1	0

0: Auto stop mode: The fan keeps working when the inverter is running. When the inverter stops, whether the fan works or not depends on the module temperature of inverter.

Function Code	Name	Description	Setting Range	Factory setting
F8.27	Restrain oscillation	0: Enabled 1: Disabled	0-1	0

The function is applicable in the instance of low network voltage or heavy load for a long time, inverter rises the output voltage with rising utilization rate of itself bus voltage

Function Code	Name	Description	Setting Range	Factory setting
F8.28	PW M mode	0: PW M mode 1 1: PW M mode 2 2: PW M mode 3	0-2	0

The features of each mode, please refer the following table:

Mode	Noise in lower frequency	Noise in higher frequency	Other
PWM mode 1	low	high	

Mode	Noise in lower frequency	Noise in higher frequency	Other
PWM mode 2	low		Need to be derated, because of higher temperature rise
PWM mode 3	high		Be more effective to restrain the oscillation

4-10 F9 Group: PID Control

ID control is a common used method in process control, such as flow, pressure and temperature control. The principle is firstly to detect the bias between preset value and feedback value, then calculate output frequency of inverter according to proportional gain, integral and differential time. Please refer to following figure.

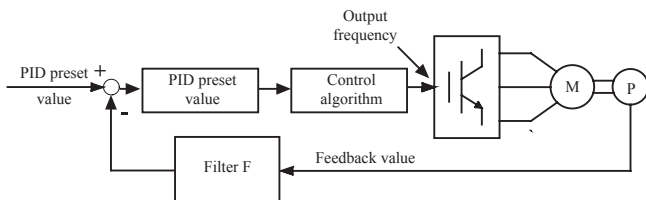

Figure 4.24 PID control diagram

Notice:

- To make PID take effect, F0.04 must be set to be 6.

Function Code	Name	Description	Setting Range	Factory setting
F9.00	PID preset source selection	0: Keypad 1: FIV 2: FIC 3: X8 4: Multi-step 5: Communication	0-5	0
F9.01	Keypad PID preset	0.0%~100.0%	0.0%~100.0%	0.0%
F9.02	PID feedback source selection	0: FIV 1: FIC 2: FIV+FIC 3: X8 4: Communication	0-4	0

These parameters are used to select PID preset and feedback source.

Notice:

- **Preset value and feedback value of PID are percentage value.**
- **100% of preset value is corresponding to 100% of feedback value.**
- **Preset source and feedback source must not be same, otherwise PID will be malfunction.**

Function Code	Name	Description	Setting Range	Factory setting
F9.03	PID output characteristic	0: Positive 1: Negative	0-1	0

0: Positive. When the feedback value is greater than the preset value, output frequency will be decreased, such as tension control in winding application.

1: Negative. When the feedback value is greater than the preset value, output frequency will be increased, such as tension control in unwinding application.

Function Code	Name	Description	Setting Range	Factory setting
F9.04	Proportional gain(Kp)	0.00~100.00	0.00~100.00	0.10
F9.05	Integral time (Ti)	0.01~10.00s	0.01~10.00s	0.10s
F9.06	Differential time(Td)	0.00~10.00s	0.00~10.00s	0.00s

Optimize the responsiveness by adjusting these parameters while driving an actual load.

Adjusting PID control:

Use the following procedure to activate PID control and then adjust it while monitoring the response.

- 1.Enabled PID control (F0.04=6).
- 2.Increase the proportional gain (Kp) as far as possible without creating oscillation.
- 3.Reduce the integral time (Ti) as far as possible without creating oscillation.
- 4.Increase the differential time (Td) as far as possible without creating oscillation.

Making fine adjustments:

First set the individual PID control constants, and then make fine adjustments.

- Reducing overshooting

If overshooting occurs, shorten the differential time and lengthen the integral time.

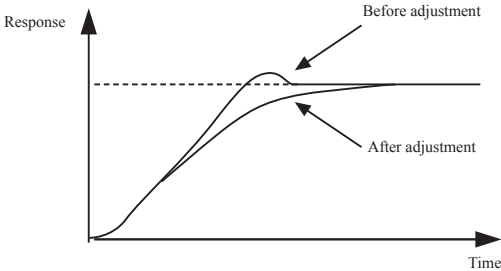

Figure 4.25 Reducing overshooting diagram.

- Rapidly stabilizing control status

To rapidly stabilize the control conditions even when overshooting occurs, shorten the integral time and lengthen the differential time.

- Reducing long-cycle oscillation

If oscillation occurs with a longer cycle than the integral time setting, it means that integral operation is strong. The oscillation will be reduced as the integral time is lengthened.

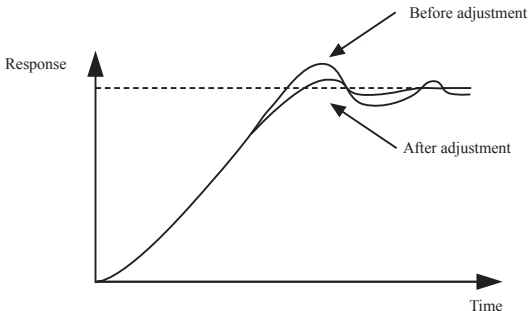

Figure 4.26 Reducing long-cycle oscillation diagram.

- Reducing short-cycle oscillation

If the oscillation cycle is short and oscillation occurs with a cycle approximately the same as the differential time setting, it means that the differential operation is strong. The oscillation will be reduced as the differential time is shortened.

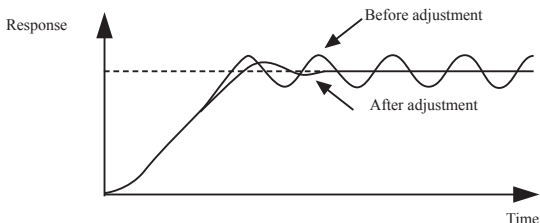

Figure 4.27 Reducing short-cycle oscillation diagram.

If oscillation cannot be reduced even by setting the differential time to 0, then either lower the proportional gain or raise the PID primary delay time constant.

Function Code	Name	Description	Setting Range	Factory setting
F9.07	Sampling cycle (T)	0.00~100.00s	0.00~100.00s	0.10s
F9.08	Bias limit	0.0~100.0%	0.0~100.0%	0.0%

Sampling cycle T refers to the sampling cycle of feedback value.

The PI regulator calculates once in each sampling cycle. The bigger the sampling cycle is, the slower the response is. Bias limit defines the maximum bias between the feedback and the preset. PID stops operation when the bias is within this range. Setting this parameter correctly is helpful to improve the system output accuracy and stability.

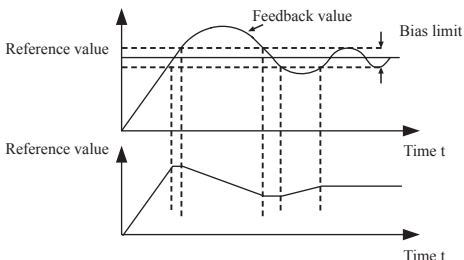

Figure 4.28 Relationship between bias limit and output frequency

Function Code	Name	Description	Setting Range	Factory setting
F9.09	Feedback lost detecting value	0.0~100.0%	0.0~100.0%	0.0%
F9.10	Feedback lost detecting time	0.0~3600.0s	0.0~3600.0s	1.0s

When feedback value is less than F9.09 continuously for the period determined by F9.10, the inverter will alarm feedback lost failure (PIDE).

Notice:

- **100% of F9.09 is the same as 100% of F9.01.**

4-11 FA Group: Simple PLC and Multi-step Speed Control

Simple PLC function can enable the inverter to change its output frequency and directions automatically according to programmable controller PLC. For multi-step speed function, the output frequency can be changed only by multi-step terminals.

Notice:

- **Simple PLC has 16 steps which can be selected.**
- **If F0.04 is set to be 5, 16 steps are available for multi-step speed. Otherwise only 15 steps are available (step 1~15).**

Function Code	Name	Description	Setting Range	Factory setting
FA.00	Simple PLC status saving after power off	0: Disabled 1: Enabled	0-1	0

This parameter determines whether the running step and output frequency should be saved when power off or not.

Function Code	Name	Description	Setting Range	Factory setting
FA.01	Simple PLC mode	0: Stop after one cycle 1: Hold last frequency FA.00 Simple PLC mode after one cycle 2: Circular run	0-2	0

- 0: Stop after one cycle: Inverter stops automatically as soon as it completes one cycle, and It needs run command to start again.
- 1: Hold last frequency after one cycle: Inverter holds frequency and direction of last step after one cycle.
- 2: Circular run: Inverter continues to run cycle by cycle until receive a stop command.

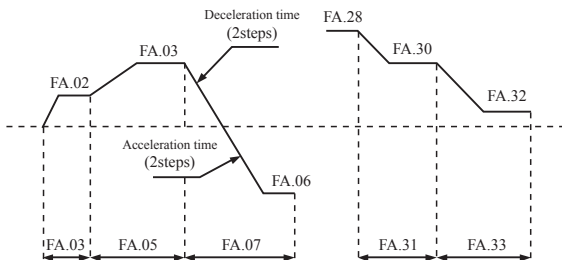

Figure 4.29 Simple PLC operation diagram.

Function Code	Name	Description	Setting Range	Factory setting
FA.02	Multi-step speed 0	-100.0~100.0%	-100.0~100.0%	0.0%
FA.03	0th Step running time	0.0~6553.5s(h)	0.0~6553.5s(h)	0.0s
FA.04	Multi-step speed 1	-100.0~100.0%	-100.0~100.0%	0.0%
FA.05	1st Step running time	0.0~6553.5s(h)	0.0~6553.5s(h)	0.0s
FA.06	Multi-step speed 2	-100.0~100.0%	-100.0~100.0%	0.0%
FA.07	2ed Step running time	0.0~6553.5s(h)	0.0~6553.5s(h)	0.0s
FA.08	Multi-step speed 3	-100.0~100.0%	-100.0~100.0%	0.0%
FA.09	3rd Step running time	0.0~6553.5s(h)	0.0~6553.5s(h)	0.0s
FA.10	Multi-step speed 4	-100.0~100.0%	-100.0~100.0%	0.0%
FA.11	4th Step running time	0.0~6553.5s(h)	0.0~6553.5s(h)	0.0s
FA.12	Multi-step speed 5	-100.0~100.0%	-100.0~100.0%	0.0%
FA.13	5th Step running time	0.0~6553.5s(h)	0.0~6553.5s(h)	0.0s
FA.14	Multi-step speed 6	-100.0~100.0%	-100.0~100.0%	0.0%
FA.15	6th Step running time	0.0~6553.5s(h)	0.0~6553.5s(h)	0.0s

Function Code	Name	Description	Setting Range	Factory setting
FA.16	Multi-step speed 7	-100.0~100.0%	-100.0~100.0%	0.0%
FA.17	7th Step running time	0.0~6553.5s(h)	0.0~6553.5s(h)	0.0s
FA.18	Multi-step speed 8	-100.0~100.0%	-100.0~100.0%	0.0%
FA.19	8th Step running time	0.0~6553.5s(h)	0.0~6553.5s(h)	0.0s
FA.20	Multi-step speed 9	-100.0~100.0%	-100.0~100.0%	0.0%
FA.21	9th Step running time	0.0~6553.5s(h)	0.0~6553.5s(h)	0.0s
FA.22	Multi-step speed 10	-100.0~100.0%	-100.0~100.0%	0.0%
FA.23	10th Step running time	0.0~6553.5s(h)	0.0~6553.5s(h)	0.0s
FA.24	Multi-step speed 11	-100.0~100.0%	-100.0~100.0%	0.0%
FA.25	11th Step running time	0.0~6553.5s(h)	0.0~6553.5s(h)	0.0s
FA.26	Multi-step speed 12	-100.0~100.0%	-100.0~100.0%	0.0%
FA.27	12th Step running time	0.0~6553.5s(h)	0.0~6553.5s(h)	0.0s
FA.28	Multi-step speed 13	-100.0~100.0%	-100.0~100.0%	0.0%
FA.29	13th Step running time	0.0~6553.5s(h)	0.0~6553.5s(h)	0.0s
FA.30	Multi-step speed 14	-100.0~100.0%	-100.0~100.0%	0.0%
FA.31	14th Step running time	0.0~6553.5s(h)	0.0~6553.5s(h)	0.0s
FA.32	Multi-step speed 15	-100.0~100.0%	-100.0~100.0%	0.0%
FA.33	15th Step running time	0.0~6553.5s(h)	0.0~6553.5s(h)	0.0s

Notice:

- 100% of multi-step speed x corresponds to the maximum frequency (F0.10).
- If the value of multi-step speed x is negative, the direction of this step will be reverse, otherwise it will be forward.
- The unit of x step running time is determined by FA.37.

Selection of step is determined by combination of multi-step terminals. Please refer to following figure and table.

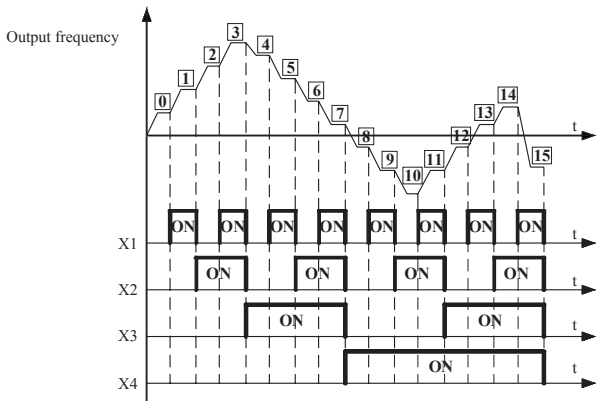

Figure 4.30 Multi-steps speed operation diagram

Terminal Step	Multi-step speed reference 1	Multi-step speed reference 2	Multi-step speed reference 3	Multi-step speed reference 4
0	OFF	OFF	OFF	OFF
1	ON	OFF	OFF	OFF
2	OFF	ON	OFF	OFF
3	ON	ON	OFF	OFF
4	OFF	OFF	ON	OFF
5	ON	OFF	ON	OFF
6	OFF	ON	ON	OFF
7	ON	ON	ON	OFF
8	OFF	OFF	OFF	ON
9	ON	OFF	OFF	ON
10	OFF	ON	OFF	ON
11	ON	ON	OFF	ON
12	OFF	OFF	ON	ON
13	ON	OFF	ON	ON
14	OFF	ON	ON	ON
15	ON	ON	ON	ON

Function Code	Name	Description	Setting Range	Factory setting
FA.34	ACC/DEC time selection for step 0-7	0~0XFFFF	0~0XFFFF	0

Function Code	Name	Description	Setting Range	Factory setting
FA.35	ACC/DEC time selection for step 8-15	0~0XFFFF	0~0XFFFF	0

These parameters are used to determine the ACC/DEC time from one step to next step.

There are four ACC/DEC time groups.

Function Code	Binary Dight		Step No	ACC/DEC Time 0	ACC/DEC Time 1	ACC/DEC Time 2	ACC/DEC Time 3
FA 34	BIT 1	BIT 0	0	00	01	10	11
	BIT 3	BIT 2	1	00	01	10	11
	BIT 5	BIT 4	2	00	01	10	11
	BIT 7	BIT 6	3	00	01	10	11
	BIT 9	BIT 8	4	00	01	10	11
	BIT 11	BIT 10	5	00	01	10	11
	BIT 3	BIT 12	6	00	01	10	11
FA 35	BIT 15	BIT 14	7	00	01	10	11
	BIT 1	BIT 0	8	00	01	10	11
	BIT 3	BIT 2	9	00	01	10	11
	BIT 5	BIT 4	10	00	01	10	11
	BIT 7	BIT 6	11	00	01	10	11
	BIT 9	BIT 8	12	00	01	10	11
	BIT 11	BIT 10	13	00	01	10	11
	BIT 3	BIT 12	14	00	01	10	11
	BIT 15	BIT 14	15	00	01	10	11

For example: To set the acceleration time of following table:

Step No	0	1	2	3	4	5	6	7	8	9	10	11	12	13	14	15
ACC/DEC time group	0	1	2	3	2	1	3	0	3	3	2	0	0	0	2	2

The value of every bit of FA 34 and FA 35 is:

Low byte	BIT 0	BIT 1	BIT 2	BIT 3	BIT 4	BIT 5	BIT 6	BIT 7
FA 34	0	0	1	0	0	1	1	1
FA 35	1	1	1	1	0	1	0	0

High byte	BIT 8	BIT 9	BIT 10	BIT 11	BIT12	BIT 13	BIT 14	BIT 15
FA 34	0	1	1	0	1	1	0	0
FA 35	0	0	0	0	0	1	0	1

So the value of FA 34 should be: 0X36 E4, the value of FA 35 should be: 0XA02F

Function Code	Name	Description	Setting Range	Factory setting
FA.36	Simple PLC restart selection	0: Restart from step 0 1: Continue from paused	0--1	0

0: Restart from step 0: If the inverter stops during running (due to stop command or fault),

it will run from step 0 when it restarts.

1: Continue from interrupted step: If the inverter stops during

running (due to stop command or fault), it will record the running

time of current step. When inverter restarts,

it will resume from interrupted time automatically. For details, please refer to following figure.

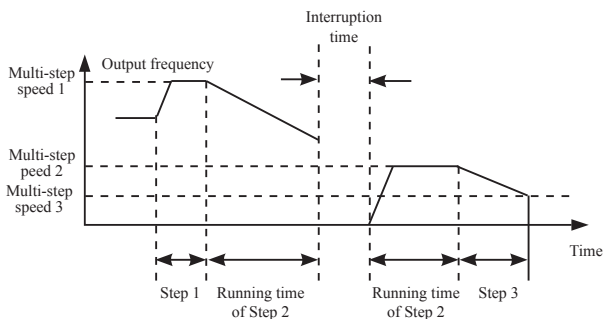

Figure 4.31 Simple PLC continues from interrupted step.

Function Code	Name	Description	Setting Range	Factory setting
FA.37	Time unit	0: Second 1: Minute	0-1	0

This parameter determines the unit of x step running time.

4-12 Fb Group: Protection Function

Function Code	Name	Description	Setting Range	Factory setting
Fb.00	Motor overload protection	0: Disabled 1: Normal motor 2: Variable frequency motor	0-2	0

1: For normal motor, the lower the speed is, the poorer the cooling effect is. Based on this reason, if output frequency is lower than 30Hz, inverter will reduce the motor overload protection threshold to prevent normal motor from overheat.

2: As the cooling effect of variable frequency motor has nothing to do with running speed, it is not required to adjust the motor overload protection threshold.

Function Code	Name	Description	Setting Range	Factory setting
Fb.01	Motor overload protection current	20.0% ~ 120.0% (rated current of the motor)	20.0% ~ 120.0% (rated current of the motor)	100.0%

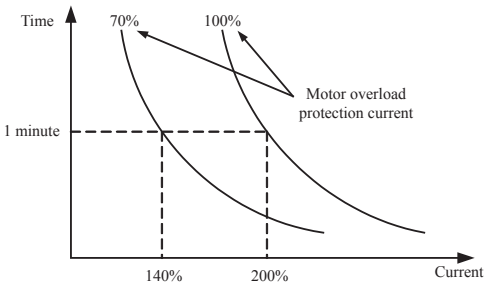

Figure 4.32 Motor overload protection curve.

he value can be determined by the following formula:

Motor overload protection current = (Maximum load current / inverter rated current) * 100%

Notice:

- This parameter is normally used when rated power of inverter is greater than rated power of motor.

- **Motor overload protection time: 60s with 200% of rated current. For details, please refer to above figure.**

Function Code	Name	Description	Setting Range	Factory setting
Fb.02	Input phase-failure protection	0: Disable 1: Enable	0-1	1
Fb.03	Output phase-failure protection	0: Disable 1: Enable	0-1	1

Notice:

- **Please be cautious to set these parameters as disabled.**

Otherwise it may cause inverter and motor overheat even damaged.

Function Code	Name	Description	Setting Range	Factory setting
Fb.04	Threshold of trip-free	70.0.0~110.0% (standard bus voltage)	70.0.0~110.0% (standard bus voltage)	80.0%
Fb.05	Decrease rate of trip-free	0.00Hz~F0.10	0.00Hz~F0.10	0.00Hz

If Fb.05 is set to be 0, the trip-free function is invalid.

Trip-free function enables the inverter to perform low-voltage compensation when DC bus voltage drops below Fb.04. The inverter can continue to run without tripping by reducing its output frequency and feedback energy via motor.

Notice:

- **If Fb.05 is too big, the feedback energy of motor will be too large and may cause over-voltage fault. If Fb.05 is too small, the feedback energy of motor will be too small to achieve voltage compensation effect. So please set FB.05 according to load inertia and the actual load.**

Function Code	Name	Description	Setting Range	Factory setting
Fb.06	Over-voltage stall protection	0: Disable 1: Enable	0-1	1
Fb.07	Over-voltage stall protection point	110~150%	110~150%	380V: 130% 220V: 120%

During deceleration, the motor's decelerating rate may be lower than that of inverter's output frequency due to the load inertia. At this time, the motor will feed the energy back to the inverter, resulting in rise of DC bus voltage. If no measures taken, the inverter will trip due to over voltage.

During deceleration, the inverter detects DC bus voltage and compares it with over-voltage stall protection point. If DC bus voltage exceeds Fb.07, the inverter will stop reducing its output frequency. When DC bus voltage become lower than Fb.07, the deceleration continues, as shown in following figure.

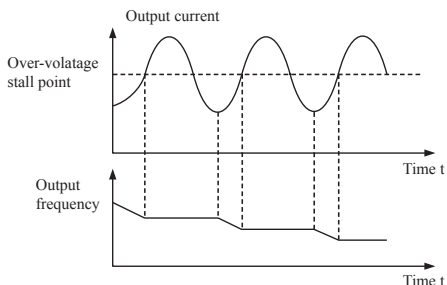

Figure 4.33 Over-voltage stall function.

Function Code	Name	Description	Setting Range	Factory setting
Fb.08	Auto current limiting threshold	50~200%	50~200%	GModel:160% PModel:120%
Fb.09	Frequency decrease rate when current limiting	0.00~50.00 Hz/s	0.00~50.00 Hz/s	10.00Hz/s
Fb.10	Auto current limiting selection	0: Disable 1: Enable when constant speed	0-1	0

Auto current limiting is used to limit the current of inverter smaller than the value determined by Fb.08 in real time. Therefore the inverter will not trip due to surge over-current. This function is

especially useful for the applications with big load inertia or step change of load.

Fb.08 is a percentage of the inverter's rated current.

Fb.09 defines the decrease rate of output frequency when this function is active. If Fb.08 is too small, overload fault may occur. If it is too big, the frequency will change too sharply and therefore, the feedback energy of motor will be too large and may cause over-voltage fault. This function is always enabled during acceleration or deceleration. Whether the function is enabled in constant Speed running is determined by Fb.10.

Notice:

- **During auto current limiting process, the inverter's output frequency may change; therefore, it is recommended not to enable the function when inverter needs to output stable frequency.**

- **During auto current limiting process, if Fb.08 is too low, the overload capacity will be impacted.**

Please refer to following figure.

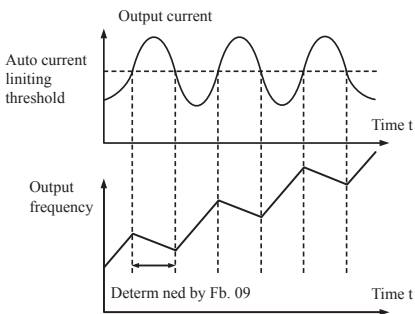

Figure 4.34 Current limiting protection function.

Function Code	Name	Description	Setting Range	Factory setting
Fb.11	overtorque (OL3)	0:No detection 1:Valid detection of overtorque during running, then continue running 2:Valid detection of overtorque during running, then waring and sto 3:Valid detection of overtorque during constant speed running, then continue running 4:Valid detection of overtorque during constant speed running, then waring and stop.	0-4	1
Fb.12	Detection level of overtorque	1.0%~200.0%	1.0%~200.0%	Depend on Mode
Fb.13	Detection time of overtorque	0.0~60.0s	0.0~60.0s	0.1s
Fb.14	reserve			
Fb.15	reserve			

4-13 FC Group: Serial Communication

Function Code	Name	Description	Setting Range	Factory setting
FC.00	Baud rate selection	0: 1200BPS 1: 2400BPS 2: 4800BPS 3: 9600BPS 4: 19200BPS 5: 38400BPS	0-5	3

This parameter can set the data transmission rate during serial communication.

Notice:

- The baud rate of master and slave must be the same.

Function Code	Name	Description	Setting Range	Factory setting
FC.01	Data format	0: RTU, 1 start bit, 8 data bits, no parity check, 1 stop bit. 1: RTU, 1 start bit, 8 data bits, even parity check, 1 stop bit. 2: RTU, 1 start bit, 8 data bits, odd parity check, 1 stop bit. 3: RTU, 1 start bit, 8 data bits, no parity check, 2 stop bits. 4: RTU, 1 start bit, 8 data bits, even parity check, 2 stop bits. 5: RTU, 1 start bit, 8 data bits, odd parity check, 2 stop bits.	0-5	0
FC.02	Local address	0~247, 0 stands for the broadcast address	0-247	0

This parameter determines the slave address used for communication with master. The value "0" is the broadcast address.

Function Code	Name	Description	Setting Range	Factory setting
FC.03	Communication delay time	0~200ms	0~200ms	5ms

This parameter can be used to set the response delay in communication in order to adapt to the MODBUS master. In RTU mode, the actual communication delay should be no less than 3.5 characters' interval.

Function Code	Name	Description	Setting Range	Factory setting
FC.04	Communication timeout delay	0.0: Disabled 0.1~100.0s	0.1~100.0s	0.0s

When the value is zero, this function will be disabled. When communication interruption is longer than the non-zero value of FC.04, the inverter will alarm communication error.

Function Code	Name	Description	Setting Range	Factory setting
FC.05	Communication error action	0:alarm and coast to stop 1:No alarm and continue to run 2:No alarm but stop according to F6.06(If F0.02=2) 3:No alarm but stop according to F6.06(all control mode)	0-3	1

0: When communication error occurs, inverter will alarm (CE) and coast to stop.

1: When communication error occurs, inverter will omit the error and continue to run.

2: When communication error occurs, if F0.01=2, inverter will not alarm but stop according to stop mode determined by F6.06.

Otherwise it will omit the error.

3: When communication error occurs, inverter will not alarm but stop according to stop mode determined by F6.06

Function Code	Name	Description	Setting Range	Factory setting
FC.06	Response action	Unit's place of LED 0: Response to writing 1: No response to writing Ten's place of LED 0: Reference not saved when power off 1: Reference saved when power off	0-1	00

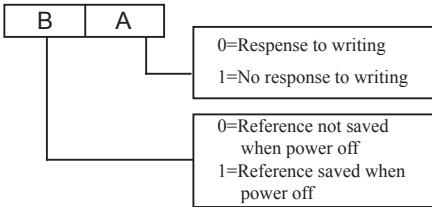

Figure 4.35 Meaning of FC.06.

A stands for: Unit's place of LED. B stands for: Ten's place of LED.

Chapter 5 Trouble Shooting

5.1 Fault and Trouble shooting

Fault code	Fault Type	Reason	Solution
UC1	IGBT Ph-U fault	1. Acc/Dec time is too short 2. IGBT module fault 3. Malfunction caused by interference 4. Grounding is not properly	1. Increase Acc/Dec time 2. Ask for support 3. Inspect external equipment and eliminate interference
UC2	IGBT Ph-V fault		
UC3	IGBT Ph-W fault		
OC1	Over-cirrent when acceleration	1. Short-circuit or ground fault occurred at inverter output 2. Load is too heavy or Acc/Dec time is too short 3.V/F curve is not suitable 4. sudden change of load	1. Inspect whether motor damaged insulation worn or cable damaged 2. Increase Acc/Dec time or select bigger capacity inverter 3. Check and adjust V/F curve 4. Check the load
OC2	Over-cirrent when deceleration		
OC3	Over-cirrent when constant speed running		
OU1	Over-voltage when acceleration	1.Dec time is too shord and regenerative energy from the motor is too large 2. Input voltage is too high	1. Increase Dec time or connect braking resistor 2. Decrease input voltage within specification
OU2	Over-voltage when deceleration		
OU3	Over-voltage when speed running		
LU	DC bus Under-voltage	1. Open phase occurred with power supply 2. Momentary power loss occurred 3. W iring terminals for input power supply are loose 4. Voltage fluctuations in	Inspect the input power supply or wiring

Fault code	Fault Type	Reason	Solution
OL1	Motor overload	power supply are too large 1. Motor drive heavy load at low speed for a long time 2. Improper V/F curve 3. Improper motor's overload protection threshold (PB.03) 4. Sudden change of load	1. Select variable frequency motor 2. Check and adjust V/F curve 3. Check and adjust Fb.03 4. Check the load
OL2	Inverter overload	1. Load is too heavy or Acc/Dec time is too short 2. Improper V/F curve 3. Capacity of inverter is too small	1. Increase Acc/Dec time or select bigger capacity inverter 2. Check and adjust V/F curve 3. Select bigger capacity inverter
LI	Input phase failure	1. Open-phase occurred in power supply 2. Momentary power loss occurred 3. Wiring terminals for input power supply are loose 4. Voltage fluctuations in power supply are too large 5. Voltage balance between phase is bad	Check the wiring, installation and power supply
LO	Output phase failure	1. There is a broken wire in the output cable 2. There is a broken wire in the motor winding 3. Output terminals are loose	Check the wiring and installation
EF	External fault	Sx: External fault input terminal take effect	Inspect external equipment
OH1	Rectify overheat	1. Ambient temperature is too high 2. Near heat source 3. Cooling fans of inverter stop or damaged 4. Obstruction of ventilation channel	1. Install cooling unit 2. Remove heat source 3. Replace cooling fan 4. Clear the ventilation channel
OH2	IGB overheat	5. Carrier frequency too high	5. Decrease carrier frequency

Fault code	Fault Type	Reason	Solution
CE	Communication fault	<ol style="list-style-type: none"> 1. Improper baud rate setting 2. Receive wrong date 3. Communication is interrupted for Long time 	<ol style="list-style-type: none"> 1. Set proper baud rate 2. Check communication devices and signals
IE	Current detection fault	<ol style="list-style-type: none"> 1. Wires or connectors of control board are loose 2. Hall sensor is damaged 3. Amplifying circuit is abnormal 	<ol style="list-style-type: none"> 1. Check the wiring 2. Ask for support
TE	Autotuning fault	<ol style="list-style-type: none"> 1. Improper setting of motor rated parameters 2. Overtime of autotuning 	<ol style="list-style-type: none"> 1. Set rated parameters according to motor nameplate 2. Check motor's wiring
EEP	EEPROM fault	Read/Write fault of control parameters	Press STOP/RESET to reset
PIDE	PID feedback fault	<ol style="list-style-type: none"> 1. PID feedback disconnected 2. PID feedback source disappears 	Ask for support <ol style="list-style-type: none"> 1. Inspect PID feedback signal wire 2. Inspect PID feedback source
bCE	Brake unit fault	<ol style="list-style-type: none"> 1. Braking circuit failure or brake tube damaged 2. Too low resistance of externally connected braking resistor 	<ol style="list-style-type: none"> 1. Inspect braking unit, replace braking tube 2. Increase braking resistance
END	Time reach of factory setting	<ol style="list-style-type: none"> 1. Reach the working time 	<ol style="list-style-type: none"> 1. As for service
OL3	Overtorque	<ol style="list-style-type: none"> 1. More fast acceleration 2. Restart the running motor 3. Lower DC bus voltage 4. Bigger load 	<ol style="list-style-type: none"> 1. Increase the acceleration time 2. Avoid to restart after stop 3. Check the DC bus voltage 4. Use the bigger power rating inverter 5. Set PB.11 to be the correct value

5.2 Fault and Trouble shooting

Inverter may have following faults or malfunctions during operation, please refer to the following solutions.

No display after power on:

- Inspect whether the voltage of power supply is the same as the inverter rated voltage or not with multi-meter. If the power supply has problem, inspect and solve it.
- Inspect whether the three-phase rectify bridge is in good condition or not. If the rectification bridge is burst out, ask for support.
- Check the CHARGE light. If the light is off, the fault is mainly in the rectify bridge or the buffer resistor. If the light is on, the fault may be lies in the switching power supply. Please ask for support.

Power supply air switch trips off when power on:

- Inspect whether the input power supply is grounded or short circuit. Please solve the problem.
- Inspect whether the rectify bridge has been burnt or not. If it is damaged, ask for support.

Motor doesn't move after inverter running:

- Inspect if there is balanced three-phase output among U, V, W. If yes, then motor could be damaged, or mechanically locked. Please solve it.
- If the output is unbalanced or lost, the inverter drive board or the output module may be damaged, ask for support..

Inverter displays normally when power on, but switch at the input side trips when running:

- Inspect whether the output side of inverter is short circuit. If yes, ask for support.
- Inspect whether ground fault exists. If yes, solve it.
- If trip happens occasionally and the distance between motor and inverter is too far, it is recommended to install output AC reactor.

Chapter 6 Maintenance

WARNING

- Maintenance must be performed according to designated maintenance methods.
- Maintenance, inspection and replacement of parts must be performed only by certified person.
- After turning off the main circuit power supply, wait for 10 minutes before maintenance or inspection.
- DO NOT directly touch components or devices of PCB board. Otherwise inverter can be damaged by electrostatic.
- After maintenance, all screws must be tightened.

6.1 Inspection

In order to prevent the fault of inverter to make it operate smoothly in high-performance for a long time, user must inspect the inverter periodically (within half year). The following table indicates the inspection content.

Items to be checked	Main inspections		Criteria
	Inspection content	Frequency	Means/Methods
Operation environment	1. temperature 2. humidity 3. dust 4. vapor 5. gases	1. point thermometer hygrometer 2. observation 3. visual examination and smelling	1. ambient temperature shall be lower than 40°C , otherwise, the rated values should be decreased. Humidity shall meet the requirement 2. no dust accumulation, no traces of water leakage and no condensate 3. no abnormal color and smell

Items to be checked	Main inspections		Criteria
	Inspection content	Frequency	Means/Methods
Inverter	1. vibration 2. cooling and heating 3. noise	1. point thermometer 2. comprehensive observation 3. listening	1. smooth operation without vibration 2. fan is working in good condition. Speed and air flow are normal. No abnormal heat. 3. No abnormal noise
Motor	1. vibration 2. heat 3. noise	1. comprehensive observation 2. point thermometer 3. listening	1. No abnormal vibration and no abnormal noise. 2. No abnormal heat. 3. No abnormal noise
Operation status parameters	1. power input voltage 2. inverter output voltage 3. inverter output current 4. internal temperature	1. voltmeter 2. rectifying voltmeter 3. ammeter 4. point thermometer	1. satisfying the specification 2. satisfying the specification 3. satisfying the specification 4. temperature rise is lower than 40°C

6.2 Periodic Maintenance

Customer should check the drive every 3 months or 6 months according to the actual environment.

6.2.1 Check whether the screws of control terminals are loose. If so, tighten them with a screwdriver;

6.2.2 Check whether the main circuit terminals are properly connected; whether the mains cables are over heated;

6.2.3 Check whether the power cables and control cables are damaged, check especially for any wear on the cable tube;

6.2.4 Check whether the insulating tapes around the cable lugs are stripped;

6.2.5 Clean the dust on PCBs and air ducts with a vacuum cleaner;

6.2.6 For drives that have been stored for a long time, it must be powered on every 2 years. When supplying AC power to the drive,

use a voltage regulator to raise the input voltage to rated input voltage gradually. The drive should be powered for 5 hours without load.

6.2.7 Before performing insulation tests, all main circuit input/output terminals should be short-circuited with conductors. Then proceed insulation test to the ground. Insulation test of single main circuit terminal to ground is forbidden; otherwise the drive might be damaged. Please use a 500V Mega-Ohm-Meter.

6.2.8 Before the insulation test of the motor, disconnect the motor from the drive to avoid damaging it.

6.3 Replacement of wearing parts

Fans and electrolytic capacitors are wearing part, please make periodic replacement to ensure long term, safety and failure-free operation. The replacement periods are as follows:

- ◆ Fan: Must be replaced when using up to 20,000 hours;
- ◆ Electrolytic Capacitor: Must be replaced when using up to 30,000~40,000 hours.

Chapter 7 Peripheral Devices Selection

Check the motor capacity of the inverter you purchased. Appropriate peripheral devices must be selected according to the capacity. Refer to the following list and prepare appropriate peripheral devices:

7-1 Peripheral Devices Description

Peripheral Devices Name	Description
Moulded case circuit break (MCCB) or earth leakage circuit break (ELB), fuse	The breaker must be selected carefully since an In-rush current flows in the inverter at power on.
Magnetic contactor (MC)	Install the MC to ensure safety. Do not use this MC to start and stop the inverter. Doing so will cause the inverter life to be shortened.
AC/DC Reactor	Reactor (option) should be used when power harmonics measures are taken, the power factor is to be improved or the inverter is installed near a large power supply system (1000KVA or more). The inverter may be damaged if you do not use reactors. Select the reactor according to the model. For the 160KW or less, remove the jumpers across terminals P+ and - to connect to the DC reactor. For the 250KW or more, a DC reactor is supplied. Please always install the reactor.
Noise filter	Install a noise filter to reduce the electromagnetic noise generated from the inverter. Effective in the range from about 1MHz to 10MHz. When more wires are passed through, a more effective result can be obtained.
Brake resistor and brake unit	To improve the brake capability at deceleration.
Ferrite ring	To reduce the disturbance which is generated by inverter

7-2 Applied DC reactor Specification

Applicable Inverter Type	Motor Output (kW)	DC Reactor Selection	
		Rated current (A)	Inductance value (mH)
H6200S-0R4G	0.4	3	28
H6200S-0R7G	0.75	3	28
H6200S-1R5G	1.5	6	11
H6200S-2R2G	2.2	6	11
H6200S-3R7G	3.7	23	3.6
H6400S-0R4G/0R7P	0.4/0.75	6	11
H6400S-0R7G/1R5P	0.75/1.5	6	11
H6400S-1R5G/2R2P	1.5/2.2	6	11
H6400S-2R2G/3R7P	2.2/3.7	6	11
H6400S-3R7G/5R5P	3.7/5.5	12	6.3
H6400S-5R5G/7R5P	5.5/7.5	23	3.6
H6400S-7R5G/11P	7.5/11	23	3.6
H6400S-11G/15P	11.0/15	33	2
H6400S-15G/18.5P	15/18.5	33	2
H6400S-18.5G/22P	18.5/22	40	1.3
H6400S-22G/30P	22/30	50	1.08
H6400S-30G/37P	30/37	65	0.8
H6400S-37G/45P	37/45	78	0.7
H6400S-45G/55P	45/55	95	0.54
H6400S-55G/75P	55/75	115	0.45
H6400S-75G/90P	75/90	160	0.36
H6400S-90G/110P	90/110	180	0.33
H6400S-110G/132P	110/132	250	0.26
H6400S-132G/160P	132/160	250	0.26
H6400S-160G/185P	160/185	340	0.18
H6400S-185G/200P	185/200	460	0.12
H6400S-200G/220P	200/220	460	0.12
H6400S-220G/250P	220/250	460	0.12
H6400S-250G/280P	250/280	500	0.12
H6400S-280G/315P	280/315	650	0.11
H6400S-315G/350P	315/350	650	0.11

H6400S-350G/400P	350/400	800	0.06
H6400S-400G/450P	400/450	800	0.06
H6400S-450G/500P	450/500	1000	0.05
H6400S-500G/560P	500/560	1200	0.04
H6400S-560G/630P	560/630	1200	0.04
H6400S-630G/710P	630/710	1200	0.04
H6400S-710G/800P	710/800	800*2	0.06
H6400S-800G/900P	800/900	800*2	0.06
H6400S-900G/1000P	900/1000	1000*2	0.05
H6400S-1000G	1000	1000*2	0.05

Install connection:

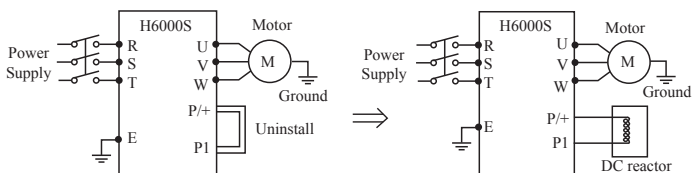

7-3 Applied AC reactor Specification

Applicable Inverter Type	Motor Output (kW)	AC Reactor Selection	
		Rated current (A)	Inductance value (mH)
H6200S-0R4G	0.4	2	7
H6200S-0R7G	0.75	2	7
H6200S-1R5G	1.5	5	3.8
H6200S-2R2G	2.2	7.5	2.5
H6200S-3R7G	3.7	20	0.75
H6400S-0R4G/0R7P	0.4/0.75	5	3.8
H6400S-0R7G/1R5P	0.75/1.5	5	3.8
H6400S-1R5G/2R2P	1.5/2.2	5	3.8
H6400S-2R2G/3R7P	2.2/3.7	7	2.5
H6400S-3R7G/5R5P	3.7/5.5	10	1.5
H6400S-5R5G/7R5P	5.5/7.5	15	1
H6400S-7R5G/11P	7.5/11	20	0.75
H6400S-11G/15P	11.0/15	30	0.6

Applicable Inverter Type	Motor Output (kW)	AC Reactor Selection	
		Rated current (A)	Inductance value (mH)
H6400S-15G/18.5P	15/18.5	40	0.42
H6400S-18.5G/22P	18.5/22	50	0.35
H6400S-22G/30P	22/30	60	0.28
H6400S-30G/37P	30/37	80	0.19
H6400S-37G/45P	37/45	90	0.16
H6400S-45G/55P	45/55	120	0.13
H6400S-55G/75P	55/75	150	0.1
H6400S-75G/90P	75/90	200	0.12
H6400S-90G/110P	90/110	250	0.06
H6400S-110G/132P	110/132	250	0.06
H6400S-132G/160P	132/160	290	0.04
H6400S-160G/185P	160/185	330	0.04
H6400S-185G/200P	185/200	400	0.04
H6400S-200G/220P	200/220	490	0.03
H6400S-220G/250P	220/250	490	0.03
H6400S-250G/280P	250/280	530	0.03
H6400S-280G/315P	280/315	600	0.02
H6400S-315G/350P	315/350	660	0.02
H6400S-350G/400P	350/400	800	0.0175
H6400S-400G/450P	400/450	800	0.0175
H6400S-450G/500P	450/500	1000	0.014
H6400S-500G/560P	500/560	1200	0.011
H6400S-560G/630P	560/630	1200	0.011
H6400S-630G/710P	630/710	1200	0.011
H6400S-710G/800P	710/800	1800	0.008
H6400S-800G/900P	800/900	1800	0.008
H6400S-900G/1000P	900/1000	1800	0.008
H6400S-1000G	1000	1800	0.008

Installation:

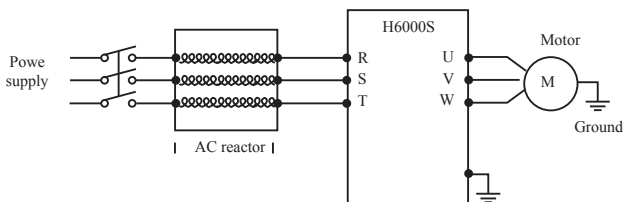

7-4 Applied Braking resistor Specification

Applicable Inverter Type	Brake resistor		Brake Unit CDBR	Brake Torque (10% ED)	Motor Output (kW)
	Power (W)	Resistance value Ω			
H6200S-0R4G	80	400	embedded	125	0.4
H6200S-0R7G	80	200		125	0.75
H6200S-1R5G	260	130		125	1.5
H6200S-2R2G	260	80		125	2.2
H6200S-3R7G	400	48		125	3.7
H6400S-0R4G/0R7P	80	750		125	0.4/0.75
H6400S-0R7G/1R5P	80	750		125	0.75/1.5
H6400S-1R5G/2R2P	300	400		125	1.5/2.2
H6400S-2R2G/3R7P	300	150		125	2.2/3.7
H6400S-3R7G/5R5P	400	150		125	3.7/5.5
H6400S-5R5G/7R5P	520	100		125	5.5/7.5
H6400S-7R5G/11P	1040	50		125	7.5/11
H6400S-11G/15P	1040	50		125	11.0/15
H6400S-15G/18.5P	1500	40		125	15/18.5
H6400S-18.5G/22P	6000	20	optional (embedded)	125	18.5/22
H6400S-22G/30P	6000	20		125	22/30
H6400S-30G/37P	6000	20		125	30/37
H6400S-37G/45P	9600	13.6	external	125	37/45
H6400S-45G/55P	9600	13.6		125	45/55
H6400S-55G/75P	9600	13.6		125	55/75
H6400S-75G/90P	9600*2	13.6/2		125	75/90
H6400S-90G/110P	9600*2	13.6/2		125	90/110

Applicable Inverter Type	Brake resistor		Brake Unit CDBR	Brake Torque (10% ED)	Motor Output (kW)
	Power (W)	Resistance value Ω			
H6400S-110G/132P	9600*2	13.6/2	external	125	110/132
H6400S-132G/160P	30000	4		125	132/160
H6400S-160G/185P	30000	4		125	160/185
H6400S-185G/200P	40000	3		125	185/200
H6400S-200G/220P	40000	3		125	200/220
H6400S-220G/250P	40000	3		125	220/250
H6400S-250G/280P	60000	2		125	250/280
H6400S-280G/315P	60000	2		125	280/315
H6400S-315G/350P	60000	2		125	315/350
H6400S-350G/400P	40000*2	1.5		125	350/400
H6400S-400G/450P	40000*2	1.5		125	400/450
H6400S-450G/500P	60000*2	1		125	450/500
H6400S-500G/560P	60000*2	1		125	500/560
H6400S-560G/630P	60000*2	1		125	560/630
H6400S-630G/710P	60000*2	1		125	630/710
H6400S-710G/800P	60000*4	0.5		125	710/800
H6400S-800G/900P	60000*4	0.5		125	800/900
H6400S-900G/1000P	60000*4	0.5		125	900/1000
H6400S-1000G	60000*4	0.5		125	1000

Calculate of Braking resistor value:

The Braking resistor value is related to the DC currency when the inverter braking. For 380V power supply, the braking DC voltage is 800V-820V, and for 220V system, the DC voltage is 400V.

Moreover, the Braking resistor value is related to braking torque $M_{br}\%$, and to the differeH braking torque the Braking resistor values are differeH, and the calculation formula is as follow:

$$R = \frac{U_{dc}^2 \times 100}{P_{Motor} \times M_{br}\% \times \eta_{Transducer} \times \eta_{Motor}}$$

Thereinto: U_{dc} ——Braking DC voltage;
 P_{Motor} ——Motor power;
 M_{br} ——Braking torsion;
 η_{Motor} ——Motor efficiency;
 $\eta_{Transducer}$ ——Transducer efficiency.

The braking power is related to braking torque and braking frequency. the foregoing illustration gives the braking torque as 125% and the frequency is 10%, and according to the different loading situations, the numbers in the illustration are for reference.

Appendix A

List of Function Parameters

Notice:

FE group is factory reserved, users are forbidden to access these parameters.

The column “Modify” determines the parameter can be modified or not.

“Δ” indicates that this parameter can be modified all the time.

“▲” indicates that this parameter cannot be modified during the inverter is running.

“●” indicates that this parameter is read only.

“Factory Setting” indicates the value of each parameter while restoring the factory parameters, but those detected parameters or record values cannot be restored.

Function Code	Name	Description	Factory Setting	Modify	Serial No.
F0 Group: Basic Function					
F0.00	Inverter model	0: G model 1: P model	0	▲	0
F0.01	Control model	0:V/F control 1:Sensorless vector control 2:Torque control (sensorless vector control)	0	▲	1

Appendix A List of Function Parameters

Function Code	Name	Description	Factory Setting	Modify	Serial No.
F0.02	Run command source	0:Keypad (LEDextinguished) 1:Terminal (LEDflickering) 2: Communication (LEDlights on)	0	△	2
F0.03	Frequency command selection	0:X; 1:Y; 2:X+Y; 3:MAX(X,Y)	0	△	3
F0.04	Frequency X command source	0:Keypad; 1:FIV; 2:FIC; 3:X8; 4:Simple PLC; 5:Multi-step speed; 6:PID; 7:Communication	0	△	4
F0.05	Frequency Y command source	0:FIV;1:FIC;2:X8	0	△	5
F0.06	Scale of frequency Y command	0: Maximum frequency 1: Frequency X command	0	△	6
F0.07	Acceleration time1	0.1~3600.0s	Depend on Mode	△	7
F0.08	Deceleration time1	0.1~3600.0s	Depend on Mode	△	8
F0.09	UP/DOWN setting	0:Valid, save UP/DOWN value when power off 1: Valid, do not saveUP/DOWN value when power off 2: Invalid 3: Valid during running, clear when stop.	0	△	9
F0.10	Maximum frequency	10.00~600.00Hz	50.00 Hz	▲	10
F0.11	Upper frequency limi	F0.12~F0.10	50.00 Hz	△	11
F0.12	Lower frequency limi	0.00~F0.11	0.00 Hz	△	12

Function Code	Name	Description	Factory Setting	Modify	Serial No.
F0.13	Keypad reference frequency	0.00~F0.10	50.00 Hz	△	13
F0.14	Running direction selection	0: Forward 1: Reverse 2: Forbid reverse	0	▲	14
F0.15	Carrier frequency	1.0~15.0kHz	Depend on Mode	△	15
F0.16	Restore parameters	0: No action 1: Restore factory setting 2: Clear fault records	0	▲	16
F0.17	AVR function	0~2	1	△	17
F0.18	Motor parameters autotuning	0:no action; 1:Rotation autotuning; 2:Static autotuning	0	▲	18
F1 Group: Motor Parameters					
F1.00	Motor rated power	0.4~3000.0kW	Depend on Mode	▲	19
F1.01	Motor rated frequency	10.00Hz~F0.10	Depend on Mode	▲	20
F1.02	Motor rated speed	0~36000rpm	Depend on Mode	▲	21
F1.03	Motor rated voltage	0~800V	Depend on Mode	▲	22
F1.04	Motor rated current	0.8~6000.0A	Depend on Mode	▲	23
F1.05	Motor stator resistance	0.001~65.535Ω	Depend on Mode	△	24
F1.06	Motor rotor resistance	0.001~65.535Ω	Depend on Mode	△	25
F1.07	Motor leakage inductance	0.1~6553.5mH	Depend on Mode	△	26
F1.08	Motor mutual inductance;	0.1~6553.5mH	Depend on Mode	△	27
F1.09	Current without load	0.01~6553.5A	Depend on Mode	△	28
F2 Group: Vector Control					

Appendix A List of Function Parameters

Function Code	Name	Description	Factory Setting	Modify	Serial No.
F2.00	ASR proportional gain Kp1	0~100	20	△	29
F2.01	ASR integral time Ki1	0.01~10.00s	0.50s	△	30
F2.02	ASR switching point1	0.00Hz~F2.05	5.00Hz	△	31
F2.03	ASR proportional gain Kp2	0~100	25	△	32
F2.04	ASR integral time Ki2	0.01~10.00s	1.00s	△	33
F2.05	ASR switching point2	F2.02—F0.10	10.0Hz	△	34
F2.06	Slip compensation rate of VC	50.0%~200.0%	100%	△	35
F2.07	Torque upper limit	0.0~200.0%	Depend on Mode	△	36
F2.08	Torque setting source	0:Keypad(F20.9); 1:FIV; 2:FIC; 3:X8; 4:Multi-step speed; 5: Communication	0	△	37
F2.09	Keypad torqueSetting	-200.0%~200.0%	50.0%	△	38
F2.10	Upper frequency setting source	0:Keypad(F0.11); 1:FIV; 2:FIC; 3:X8; 4:Multi-step speed; 5: Communication	0	△	39
F3 Group: V/F Control					
F3.00	V/F curve selection	0:Linear curve 1: User-defined curve 2:Torque_stepdown curve (1.3 order) 3:Torque_stepdown curve (1.7 order) 4:Torque_stepdown	0	▲	40
F3.01	Torque boost	0.0%:(auto) 0.1%~10.0%	0.0%	△	41

Function Code	Name	Description	Factory Setting	Modify	Serial No.
F3.02	Torqueboostcut-off	0.0%~50.0%(motor rated frequency)	20.0%	▲	42
F3.03	V/F frequency 1	0.00Hz~ F3.05	0.00Hz	△	43
F3.04	V/F voltage 1	0.0%~100.0%	0.00Hz	△	44
F3.05	V/F frequency 2	F3.03~ F3.07	30.00Hz	△	45
F3.06	V/F voltage 2	0.0%~100.0%	0.00Hz	△	46
F3.07	V/F frequency 3	F3.05~ F1.01		△	47
F3.08	V/F voltage 3	0.0%~100.0%	0.00Hz	△	48
F3.09	Slip compensation limit	0.00~200.0%	0.0%	△	49
F3.10	Auto energy saving selection	0: Disabled 1: Enabled	0	△	50
F3.11	Low-frequency threshold of restraining oscillation	0~10	2	△	51
F3.12	High-frequency threshold of restraining oscillation	0~10	0	△	52
F3.13	Boundary of restraining oscillation	0.0~F0.10	30Hz	△	53
F4 Group: Input Terminals					

Appendix A List of Function Parameters

Function Code	Name	Description	Factory Setting	Modify	Serial No.
F4.00	X1 Terminal function	1: ON-OFF input 0: Invalid 1: Forward 2: Revere	1	▲	54
F4.01	X2 Terminal function	3: 3-wire control 4: Jog forward 5: Jog reverse 6: Coast to stop 7: Reset fault 8: Pause running 9: External fault input 10: Up command 11: DOWN command 12: ClearUP/DOWN 13: Switch betweenX andY 14: Switch betweenX andX+Y 15: Switch betweenY andX+Y	4	▲	55
F4.02	X3 Terminal function	16: Multi-step speed reference1 17: Multi-step speed reference2 18: Multi-step speed reference3 19: Multi-step speed reference4 20: Multi-step speedpause 21: ACC/DEC time selection1 22: ACC/DEC time selection2 23: Reset simple PLC 24: Pause simple PLC 25: Pause PID 26: Pause traverse operation 27: Reset traverse operation 28: Reset counter 29: Reset length 30: ACC/DEC ramp hold 31: Counter input 32: UP/DOWN invalid temporarily 33-39: Reserved	7	▲	56
F4.03	X4 Terminal function		0	▲	57
F4.04	X5 Terminal function		0	▲	58
F4.05	X6 Terminal function		0	▲	59
F4.06	X7 Terminal function		0	▲	60
F4.07	X8 terminal function		0	▲	61

Function Code	Name	Description	Factory Setting	Modify	Serial No.
F4.08	X8 selection	0: High speed pulse input 1: ON-OFF input	0	▲	62
F4.09	ON-OFF filter times	1~10	5	△	63
F4.10	FW D/REV control mode	0: 2-wire control mode 1 1: 2-wire control mode 2 2: 3-wire control mode 1 3: 3-wire control mode 2	0	△	64
F4.11	UP/DOWN setting change rate	0.01~50.00Hz/s	0.50Hz/s	△	65
F4.12	FIV lower limit	-10V~10.00V	0.00V	△	66
F4.13	FIV lower limit corresponding setting	-100.0%~100.0%	0.0%	△	67
F4.14	FIV upper limit	0.00V~10.00V	10.00V	△	68
F4.15	FIV upper limit corresponding setting	-100.0%~100.0%	100.0%	△	69
F4.16	FIV filter time constant	0.00s~10.00s	0.10s	△	70
F4.17	FIC lower limit	0.00V~10.00V	0.00V	△	71
F4.18	FIC lower limit corresponding setting	-100.0%~100.0%	0.0%	△	72
F4.19	FIC upper limit	0.00V~10.00V	10.00V	△	73
F4.20	FIC upper limit corresponding setting	-100.0%~100.0%	100.0%	△	74
F4.21	FIC filter time constant	0.00s~10.00s	0.10s	△	75
F4.22	X8 lower limit	0.0 kHz ~50.0kHz	0.0KHz	△	76
F4.23	X8 lower limit corresponding setting	-100.0%~100.0%	0.0%	△	77
F4.24	X8 upper limit	0.0 kHz ~50.0kHz	50.0 KHz	△	78

Appendix A List of Function Parameters

Function Code	Name	Description	Factory Setting	Modify	Serial No.
F4.25	X8 upper limit corresponding setting	-100.0%~100.0%	100.0%	△	79
F4.26	X8filter time constant	0.00s~10.00s	0.10s	△	80
F5 Group: Output Terminals					
F5.00	Relay RA, RB, RC output selection (Optional)	0:no output 1:running 2:run forward 3:run reverse 4:fault output 5:FDT reached 6:frequency reached 7:Zero speed running 8:preset count value reached 9:specified count value reached	4	△	81
F5.01	Relay YA, YB, YC output selection	10:length reached 11:simple PLCstep completed 12:PLC cycle completed 13:running time reached 14:upper frequency limit reached 15:lower frequency limit reached	0	△	82
F5.02	YO ON-OFF Output selection	16:ready 17:auxiliary motor1 started 18:auxiliary motor2 started 19-20:reserved	1	△	83
F5.03	YO selection	0: High-speed pulse output 1 : ON-OFF output	0	△	84

Function Code	Name	Description	Factory Setting	Modify	Serial No.
F5.04	FOV function selection	0: Running frequency 1: Reference frequency 2: Motor speed	0	△	85
F5.05	FOC function selection	3: Output current 4: Output voltage 5: Output power 6: Output torque	0	△	86
F5.06	YO function selection	7: FIV voltage 8: FIC voltage/current 9: X8 frequency	0	△	87
F5.07	FOV lower limit	00.0%~100.0%	0.0%	△	88
F5.08	FOV lower limit corresponding output	0.00V~10.00V	0.0V	△	89
F5.09	FOV upper limit	00.0%~100.0%	100.0%	△	90
F5.10	FOV upper limit corresponding output	0.00V~10.00V	10.0V	△	91
F5.11	FOC lower limit	00.0%~100.0%	0.0%	△	92
F5.12	FOC lower limit corresponding output	0.00V~10.00V	0.0V	△	93
F5.13	FOC upper limit	00.0%~100.0%	100.0%	△	94
F5.14	FOC upper limit corresponding output	0.00V~10.00V	10.0V	△	95
F5.15	YO lower limit	00.0%~100.0%	0.0%	△	96
F5.16	YO lower limit corresponding output	0.00~50.0kHz	0.0kHz	△	97
F5.17	YO upper limit	00.0%~100.0%	100.0%	△	98
F5.18	YO upper limit corresponding output	0.00~50.0kHz	50.0kHz	△	99
F6 Group: Start and Stop Control					
F6.00	Acceleration / Deceleration mode	0: Linear 1: reserved	0	▲	100

Appendix A List of Function Parameters

Function Code	Name	Description	Factory Setting	Modify	Serial No.
F6.01	Start Mode	0: Start directly 1: DC braking and start 2: Speed tracking and start	0	▲	101
F6.02	Starting frequency	0.00~10.00Hz	0.00Hz	▲	102
F6.03	Hold time of starting frequency	0.0~50.0s	0.0s	▲	103
F6.04	DC Braking current before start	0.0~150.0%	0.0%	▲	104
F6.05	DC Braking time before start	0.0~50.0s	0.0s	▲	105
F6.06	Stop mode	0: Deceleration to stop 1: Coast to stop	0	△	106
F6.07	Starting frequency of DC braking	0.00~F0.10	0.00Hz	△	107
F6.08	Waiting time before DC braking	0.0~50.0s	0.0s	△	108
F6.09	DC braking current	0.0~150.0%	0.0%	△	109
F6.10	DC braking time	0.0~50.0s	0.0s	△	110
F6.11	Dead time of FWD/REV	0.0~3600.0s	0.0s	△	111
F6.12	Action when running frequency is less than the lower frequency limit	0: running at the lower frequency limit 1: stop 2: stand-by	0	▲	112
F6.13	Delay time for restart	0.0~3600.0s	0.0s	▲	113
F6.14	Restart after power off	0: Disabled 1: Enabled	0	△	114
F6.15	Waiting time of restart	0.0~3600.0s	0.0s	△	115

Function Code	Name	Description	Factory Setting	Modify	Serial No.
F6.16	Terminal function examined when power is on	0: Disabled 1: Enabled	0	△	116
F6.17 --18	Reserved			△	117/ 118
F6.19				△	119
F7 Group: Display Interface					
F7.00	User password	0~65535	0	△	120
F7.01	Reserve			△	121
F7.02	Reserve			△	122
F7.03	JOG function selection	0:Display status switching; 1:JOG; 2: FW D/REV switching 3: Clear UP/DOWN setting 4.QUICK set mode	0	△	123
F7.04	STOP/RST function selection	0:Valid when keypad control (F0.02=0) 1:Valid when keypad or terminal control(F0.02=0or1) 2:Valid when keypad or communication control(F0.02=0or2) 3: Always valid	0	△	124
F7.05	Reserve			△	125

Appendix A List of Function Parameters

Function Code	Name	Description	Factory Setting	Modify	Serial No.
F7.06	Running status display selection1	0~0XFFFF BIT0: running frequency BIT1:Reference frequency BIT2: DC bus voltage BIT3: Output voltage BIT4: Output current BIT5: Rotation speed BIT6: Line speed BIT7: Output power BIT8: Output torque BIT9: PID preset BIT10: PID feedback BIT11:Input terminal status BIT12: Output terminal status BIT13:Torque setting value BIT14: Count value BIT15: Step No. of PLC or multi-step	0X07FF	△	126
F7.07	Running status display selection2	0~0XFFFF BIT0: FIV BIT1: FIC BIT2: X8 frequency BIT3: Load percentage of motor BIT4: Load percentage of inverter BIT5: Accumulated running time BIT6~15: Reserved	0X0000	△	127

Function Code	Name	Description	Factory Setting	Modify	Serial No.
F7.08	Stop status display selection	0~0XFFFFFF BIT0:Reference frequency BIT1: DC bus voltage BIT2: Input terminal status BIT3:Output terminal status BIT4: PID preset BIT5: PID feedback BIT6: FIV BIT7: FIC BIT8: X8 frequency BIT9: Step No. of PLC or multi-step BIT10:Torque setting value BIT11~15: Reserved	0X00FF	△	128
F7.09	Coefficient of rotatio speed	0.1~999.9% Actual mechanical speed =120*output frequency *F7.09/Number of poles of motor	100.0%	△	129
F7.10	Coefficient of line speed	0.1~999.9%Line speed=actual mechanical speed * F7.10	1.0%	△	130
F7.11	Temperature Rectify module	0~100.0°C		●	131
F7.12	Temperature IGBT module	0~100.0°C		●	132
F7.13	Software version			●	133
F7.14	Inverter rated power	0-3000KW	Depend on Mode	●	134
F7.15	Inverter rated current	0.0-6000A	Depend on Mode	●	135
F7.16	Accumulated running time	0~65535h		●	136

Appendix A List of Function Parameters

Function Code	Name	Description	Factory Setting	Modify	Serial No.
F7.17	Third latest fault type	0: Not fault 1: IGBT Ph-U fault(UC1) 2: IGBT Ph-V fault(UC2) 3: IGBT Ph-W fault(UC3) 4:Over- current 1 when 1 acceleration (OC1) 5: Over-current when deceleration (OC2) 6:Over-current when constant speed running(oc3) 7:Over-voltag when acceleration (OU1) 8: Over-voltage when deceleration (OU2)		●	137
F7.18	Second latest fault type	9:Over-voltage when constant speed running(OU3) 10DCbusUnder-voltage(LU) 11: Motor overload (OL1) 12:Inverter overload(OL2) 13: Input phase failure(LI) 14: Output phase failure(LO) 15:Rectify overheat(OH1)		●	138
F7.19	Latest fault type	16: IGBT overheat (OH2) 17: External fault (EF) 18: Communication fault(CE) 19: Current detection fault(IE) 20: Autotuning fault (TE) 21: EEPROM fault (EEP) 22: PID feedback fault(PIDE) 23: Brake unit fault (bCE) 24: Time reached 25:OL3		●	139
F7.20	Output frequency at current fault			●	140

Function Code	Name	Description	Factory Setting	Modify	Serial No.
F7.21	Output current at current fault			●	141
F7.22	DC bus voltage at current fault			●	142
F7.23	input terminal status at current fault			●	143
F7.24	Output terminal status at current fault			●	144
F8 Group: Enhanced Function					
F8.00	Jog reference	0.00~F0.10	5.00hz	△	145
F8.01	Jog acceleration time	0.1~3600.0s	Depend on Mode	△	146
F8.02	Jog deceleration time	0.1~3600.0s	Depend on Mode	△	147
F8.03	Acceleration time 2	0.1~3600.0s	Depend on Mode	△	148
F8.04	Deceleration time2	0.1~3600.0s	Depend on Mode	△	149
F8.05	Acceleration time 3	0.1~3600.0s	Depend on Mode	△	150
F8.06	Deceleration time3	0.1~3600.0s	Depend on Mode	△	151
F8.07	Acceleration time 4	0.1~3600.0s	Depend on Mode	△	152
F8.08	Deceleration time4	0.1~3600.0s	Depend on Mode	△	153
F8.09	Skip Frequency 1	0.00~F0.10	0.00hz	△	154
F8.10	Skip Frequency 2	0.00~F0.10	0.00hz	△	155
F8.11	Skip Frequency bandwidth	0.00~F0.10	0.00hz	△	156
F8.12	Traverse amplitude	0.0~100.0%	0.0%	△	157

Appendix A List of Function Parameters

Function Code	Name	Description	Factory Setting	Modify	Serial No.
F8.13	Jitter frequency	0.0~50.0%	0.0%	△	158
F8.14	Rise time of traverse	0.1~3600.0s	5.0s	△	159
F8.15	Fall time of traverse	0.1~3600.0s	5.0s	△	160
F8.16	Auto reset times	0~3	0	△	161
F8.17	Reset interval	0.1~100.0s	1.0s	△	162
F8.18	Preset count value	F8.19~65535	0	△	163
F8.19	Specified count value	0~F8.18	0	△	164
F8.20	Preset running time	0~65535h	65535h	△	165
F8.21	FDT level	0.00~ F0.10	50.00Hz	△	166
F8.22	FDT lag	0.0~100.0%	5.0%	△	167
F8.23	Frequency arrive detecting range	0.0~100.0%(maximum frequency)	0.0%	△	168
F8.24	Droop control	0.00~10.00Hz	0.00Hz	△	169
F8.25	Brake threshold voltage	115.0~140.0%	Depend on Mode	△	170
F8.26	Cooling fan control	0: Auto stop mode 1: Always working	0	△	171
F8.27	Restrain oscillation	0: Enabled 1: Disabled	1	△	172
F8.28	PW M mode	0: PW M mode 1 1: PW M mode 2 2: PW M mode 3	0	▲	173
F9 Group: PID Control					
F9.00	PID preset source selection	0: Keypad 1: FIV 2: FIC 3: X8 4: Multi-step 5: Communication	0	△	174
F9.01	Keypad PID preset	0.0%~100.0%	0.0%	△	175

Function Code	Name	Description	Factory Setting	Modify	Serial No.
F9.02	PID feedback source selection	0: FIV 1: FIC 2:FIV+FIC 3: X8 4: Communication	0	△	176
F9.03	PID output characteristic	0: Positive 1: Negative	0	△	177
F9.04	Proportional gain(Kp)	0.00~100.00	0.10	△	178
F9.05	Integral time (Ti)	0.01~10.00s	0.10s	△	179
F9.06	Differential time(Td)	0.00~10.00s	0.00s	△	180
F9.07	Sampling cycle (T)	0.00~100.00s	0.10s	△	181
F9.08	Bias limit	0.0~100.0%	0.0%	△	182
F9.09	Feedback lost detecting value	0.0~100.0%	0.0%	△	183
F9.10	Feedback lost detecting time	0.0~3600.0s	1.0s	△	184
FA Group: Simple PLC and Multi-step Speed Control					
FA.00	Simple PLC status saving after power off	0: Disabled 1: Enabled	0	△	185
FA.01	Simple PLC mode	0: Stop after one cycle 1: Hold lastfrequency FA.00 Simple PLC modeafter one cycle 2: Circular run	0	△	186
FA.02	Multi-step speed 0	-100.0~100.0%	0.0%	△	187
FA.03	0th Step running time	0.0~6553.5s(h)	0.0s	△	188
FA.04	Multi-step speed 1	-100.0~100.0%	0.0%	△	189
FA.05	1st Step running time	0.0~6553.5s(h)	0.0s	△	190
FA.06	Multi-step speed 2	-100.0~100.0%	0.0%	△	191

Appendix A List of Function Parameters

Function Code	Name	Description	Factory Setting	Modify	Serial No.
FA.07	2ed Step running time	0.0~6553.5s(h)	0.0s	△	192
FA.08	Multi-step speed 3	-100.0~100.0%	0.0%	△	193
FA.09	3rd Step running time	0.0~6553.5s(h)	0.0s	△	194
FA.10	Multi-step speed 4	-100.0~100.0%	0.0%	△	195
FA.11	4th Step running time	0.0~6553.5s(h)	0.0s	△	196
FA.12	Multi-step speed 5	-100.0~100.0%	0.0%	△	197
FA.13	5th Step running time	0.0~6553.5s(h)	0.0s	△	198
FA.14	Multi-step speed 6	-100.0~100.0%	0.0%	△	199
FA.15	6th Step running time	0.0~6553.5s(h)	0.0s	△	200
FA.16	Multi-step speed 7	-100.0~100.0%	0.0%	△	201
FA.17	7th Step running time	0.0~6553.5s(h)	0.0s	△	202
FA.18	Multi-step speed 8	-100.0~100.0%	0.0%	△	203
FA.19	8th Step running time	0.0~6553.5s(h)	0.0s	△	204
FA.20	Multi-step speed 9	-100.0~100.0%	0.0%	△	205
FA.21	9th Step running time	0.0~6553.5s(h)	0.0s	△	206
FA.22	Multi-step speed 10	-100.0~100.0%	0.0%	△	207
FA.23	10th Step running time	0.0~6553.5s(h)	0.0s	△	208
FA.24	Multi-step speed 11	-100.0~100.0%	0.0%	△	209

Function Code	Name	Description	Factory Setting	Modify	Serial No.
FA.25	11th Step running time	0.0~6553.5s(h)	0.0s	△	210
FA.26	Multi-step speed 12	-100.0~100.0%	0.0%	△	211
FA.27	12th Step running time	0.0~6553.5s(h)	0.0s	△	212
FA.28	Multi-step speed 13	-100.0~100.0%	0.0%	△	213
FA.29	13th Step running time	0.0~6553.5s(h)	0.0s	△	214
FA.30	Multi-step speed 14	-100.0~100.0%	0.0%	△	215
FA.31	14th Step running time	0.0~6553.5s(h)	0.0s	△	216
FA.32	Multi-step speed 15	-100.0~100.0%	0.0%	△	217
FA.33	15th Step running time	0.0~6553.5s(h)	0.0s	△	218
FA.34	ACC/DEC time selection for step 0-7	0~0XFFFF	0	△	219
FA.35	ACC/DEC time selection for step 8-15	0~0XFFFF	0	△	220
FA.36	Simple PLC restart selection	0: Restart from step 0 1: Continue from paused	0	▲	221
FA.37	Time unit	0: Second 1: Minute	0	▲	222
Fb Group: Protection Function					
Fb.00	Motor overload protection	0: Disabled 1: Normal motor 2: Variable frequency motor	2	▲	223
Fb.01	Motor overload protection current	20.0%~120.0% (rated current of the motor)	100.0%	△	224
Fb.02	Input phase-failure protection	0: Disable 1: Enable	1	△	225

Appendix A List of Function Parameters

Function Code	Name	Description	Factory Setting	Modify	Serial No.
Fb.03	Outputphase-failure protectio	0: Disable 1: Enable	1	△	226
Fb.04	Threshold of trip-free	70.0.0~110.0% (standard bus voltage)	80.0%	△	227
Fb.05	Decrease rate of trip-free	0.00Hz~F0.10	0.00Hz	△	228
Fb.06	Over-voltage stall protection	0: Disable 1: Enable	1	△	229
Fb.07	Over-voltage stall protection poin	110~150%	80V: 130% 220V: 120%	△	230
Fb.08	Auto current limiting threshold	50~200%	GModel: 160% PModel: 120%	△	231
Fb.09	Frequency decrease rate when current limiting	0.00~50.00Hz/s	10.00 Hz/s	△	232
Fb.10	Auto current limiting selection	0: Disable 1: Enable when constant speed	0	△	233
Fb.11	overtorque (OL3)	0:No detection 1:Valid detection of overtorque during running, then continue running 2:Valid detection of overtorque during running, then waring and sto 3:Valid detection of overtorque during constant speed running, then continue running 4:Valid detection of overtorque during constant speed running, then waring and stop	1	△	234
Fb.12	Detection level ofovertorque	1.0%~200.0%	Depend on Mode	△	235

Function Code	Name	Description	Factory Setting	Modify	Serial No.
Fb.13	Detection time of overtorque	0.0~60.0s	0.1s	△	236
Fb.14	reserve			△	237
Fb.15	reserve			●	238
FC Group: Serial Communication					
FC.00	Baud rate selection	0: 1200BPS 1: 2400BPS 2: 4800BPS 3: 9600BPS 4: 19200BPS 5: 38400BPS	3	△	239
FC.01	Data format	0: RTU, 1 start bit, 8 data bits, no parity check, 1 stop bit. 1: RTU, 1 start bit, 8 data bits, even parity check, 1 stop bit. 2: RTU, 1 start bit, 8 data bits, odd parity check, 1 stop bit. 3: RTU, 1 start bit, 8 data bits, no parity check, 2 stop bits. 4: RTU, 1 start bit, 8 data bits, even parity check, 2 stop bits. 5: RTU, 1 start bit, 8 data bits, odd parity check, 2 stop bits.	0	△	240
FC.02	Local address	0~247, 0 stands for the broadcast address	1	△	241
FC.03	Communication delay time	0~200ms	5ms	△	242
FC.04	Communication timeoutdelay	0.0: Disabled 0.1~100.0s	0.0s	△	243

Appendix A List of Function Parameters

Function Code	Name	Description	Factory Setting	Modify	Serial No.
FC.05	Communication error action	0:alarm and coast to stop 1:No alarm and continue to run 2:No alarm but stop according to F6.06(If F0.02=2) 3:No alarm but stop according to F6.06(all control mode)	0	△	244
FC.06	Response action	Unit's place of LED 0: Response to writing 1: No response to writing Ten's place of LED 0: Reference not saved when power off 1: Reference saved whenpower off	0	△	245

Appendix B

Communication Protocol

Interfaces

RS485: asynchronous, half-duplex.

Default: 8-E-1, 19200bps. See Group PC parameter settings.

Communication Modes

The protocol is Modbus protocol. Besides the common register Read/W rite operation, it is supplemented with commands of parameters management.

The drive is a slave in the network. It communicates in 'point to point' master-slave mode. It will not respond to the command sent by the master via broadcast address.

In the case of multi-drive communication or long-distance transmission, connecting a 100~120Ω resistor in parallel with the master signal line will help to enhance the immunity to interference.

Protocol Format

Modbus protocol supports both RTU. The frame format is illustrated as follows:

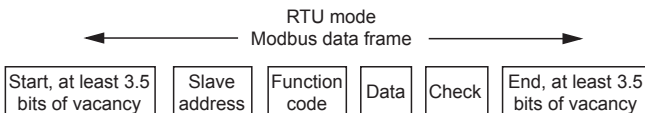

Modbus adopts "Big Endian" representation for data frame.

This means that when a numerical quantity larger than a byte is transmitted, the most significant byte is sent first.

RTU mode

In RTU mode, the Modbus minimum idle time between frames should be no less than 3.5 bytes. The checksum adopts CRC-16 method. All data except checksum itself sent will be counted into the calculation. Please refer to section: CRC Check for more information. Note that at least 3.5 bytes of Modbus idle time should be kept and the start and end idle time need not be summed up to it. The table below shows the data frame of reading parameter 002 from slave node address 1.

Node addr.	Command	Data addr.		Read No.		CRC	
0x01	0x03	0x00	0x02	0x00	0x01	0x25	0xCA

The table below shows the reply frame from slave node address 1

Node addr.	Command	Bytes No.	Data		CRC	
0x01	0x03	0x02	0x00	0x00	0xB8	0x44

Protocol function

Different respond delay can be set through drive's parameters to adapt to different needs. For RTU mode, the respond delay should be no less than 3.5 bytes interval, and for ASCII mode, no less than 1ms.

The main function of Modbus is to read and write parameters. The Modbus protocol supports the following commands:

0x03	Read inverter's function parameter and status parameters
0x06	Write single function parameter or command parameter to inverter

All drive's function parameters, control and status parameters are mapped to Modbus R/W data address.

The data address of control and status parameters please refer to the following table.

Parameter Description	Address	Meaning of value	R/W Feature
Control command	1000H	0001H: Forward	W/R
		0002H: Reverse	
		0003H: JOG forward	
		0004H: JOG reverse	
		0005H: Stop	
		0006H: Coast to stop	
		0007H: Reset fault	
		0008H: JOG stop	
Inverter status	1001H	0001H: Forward running	R
		0002H: Reverse running	
		0003H: Standby	
		0004H: Fault	
		0005H: Status of inverter POFF	
Communication setting	2000H	Communication Setting Range (-10000~10000) Note: the communication setting is the percentage of the relative value (-100.00%~100.00%). If it is set as frequency source, the value is the percentage of the maximum frequency (P0.04). If it is set as PID (preset value or feedback value), the value is the percentage of the PID	W/R
	2001H	PID setting, Range: 0~1000, 1000 means 100.0%	W/R
	2002H	PID feedback, Range: 0~1000, 1000 means 100.0%	W/R
	2003H	Setting value of torque Range: -1000~1000, 1000 means 100.0%	W/R
	2004H	Setting value of upper limit frequency (0~Fmax)	W/R

Parameter Description	Address	Meaning of value	R/W Feature
Status parameters	3000H	Output frequency	R
	3001H	Reference frequency	R
	3002H	DC Bus voltage	R
	3003H	Output voltage	R
	3004H	Output current	R
	3005H	Rotation speed	R
	3006H	Output power	R
	3007H	Output torque	R
	3008H	PID preset value	R
	3009H	PID feedback value	R
	300AH	Input terminal status	R
	300BH	Output terminal status.	R
	300CH	Input of FIV	R
	300DH	Input of FIC	R
	300EH	Reserved	R
	300FH	Reserved	R
	3010H	X8 frequency	R
	3011H	Reserved	R
	3012H	Step No. of PLC or multi-step	R
	3013H	Reserved	R
3014H	External counter input	R	
3015H	Torque setting	R	
3016H	Device code	R	

Parameter Description	Address	Meaning of value	R/W Feature
Inveter fault info address	5000H	0X00H: No fault 0X01H: UC1 0X02H: UC2 0X03H: UC3 0X04H: OC1 0X05H: OC2 0X06H: OC3 0X07H: OU1 0X08H: OU2 0X09H: OU3 0x0A: LU 0x0B: OL1 0x0C:OL2 0x0D: LI 0x0E: LO 0x0F: OH1 0x10: OH2 0x11: EF 0x12: CE 0x13: IE 0x14: tE 0x15: EEP 0x16:PIDE 0x17: bCE 0x18: END 0x19: OL3	R

The above shows the format of the frame. Now we will introduce the Modbus command and data structure in details, which is called protocol data unit for simplicity. Also MSB stands for the most significant byte and LSB stands for the least significant byte for the same reason. The description below is data format in RTU mode.

Protocol data unit format of reading parameters:

Request format:

Protocol data unit	Data length(bytes)	Range
Command	1	0x03
Data Address	2	0~0xFFFF
Read number	2	0x0001~0x0010

Reply format (success):

Protocol data unit	Data length(bytes)	Range
Command	1	0x03
Returned byte number	2	2* Read number
Content	2* Read number	

If the command is reading the type of inverter (data address 0x3016), the content value in reply message is the device code:

The high 8 bit of device code is the type of the inverter, and the low 8 bit of device code is the sub type of inverter.

For details, please refer to the following table:

High byte	Meaning	Low byte	Meaning
00	reserve	01	Vector control type
		02	For water supply
		03	Middle frequency 1500Hz
		04	Middle frequency 3000Hz
01	H6000S	01	Vector control type
		02	Middle frequency 1500Hz
02	reserve	01	Universal type
		02	Vector type H6000S

If the operation fails, the inverter will reply a message formed by failure command and error code. The failure command is (Command + 0x80). The error code indicates the reason of the error; see the table below.

Value	Name	Mean
01H	Illegal command	The command from master can not be executed. The reason maybe: 1 This command is only for new version and this version can not realize. 2 Slave is in fault status and can not execute it
02H	Illegal data address	Some of the operation addresses are invalid or not allowed to access
03H	Illegal value	When there are invalid data in the message framed received by slave. Note: This error code does not indicate the data value to write exceed the range, but indicate the message frame is a illegal frame

Value	Name	Mean
06H	Slave busy	Inverter is busy(EEPROM is storing)
10H	Password error	The password written to the password check address is not same as the password set by F7.00
11H	Check error	The CRC (RTU mode) check not passed.
12H	Written not allowed.	It only happen in write command, the reason maybe: 1 The data to write exceed the range of according parameter 2 The parameter should not be modified now. 3 The terminal has already been used.
13H	System locked	When password protection take effect and user does not unlock it, write/read the function parameter will return this error

Protocol data unit format of writing single parameter:

Request format:

Protocol data unit	Data length(bytes)	Range
Command	1	0x06
Data Address	2	0~0xFFFF
Write Content	2	0~0xFFFF

Reply format (success):

Protocol data unit	Data length(bytes)	Range
Command	1	0x06
Data Address	2	0~0xFFFF
Write Content	2	0~0xFFFF

If the operation fails, the inverter will reply a message formed by failure command and error code. The failure command is (Command + 0x80). The error code indicates the reason of the error; see table 1.

Note:

9.5.1 Between frames, the span should not less than 3.5 bytes interval, otherwise, the message will be discarded.

9.5.2 Be cautious to modify the parameters of PC group through communication, otherwise may cause the communication

interrupted.

9.5.3 In the same frame, if the span between two .near bytes more than 1.5 bytes interval, the behind bytes will be assumed as the start of next message so that communication will failure.

CRC Check

For higher speed, CRC-16 uses tables. The following are C language source code for CRC-16.

```

unsigned int crc_cal_value(unsigned char *data_value,
    unsigned char data_length)
{
    int i;
    unsigned int crc_value=0xffff;
    while(data_length--)
    {
        crc_value^=*data_value++;
        for(i=0;i<8;i++)
        {
            if(crc_value&0x0001)crc_value=(crc_value>>1)^0xa001;
            else crc_value=crc_value>>1;
        }
    }
    return(crc_value);
}

```

Example

RTU mode, read 2 data from 0004H

The request command is:

START	T1-T2-T3-T4 (transmission time of 3.5 bytes)
Node address	01H

Command	03H
High byte of start address	00H
Low byte of start address	04H
High byte of data number	00H
Low byte of data number	02H
Low byte of CRC	85H
High byte of CRC	CAH
END	T1-T2-T3-T4 (transmission time of 3.5 bytes)

The reply is :

START	T1-T2-T3-T4 (transmission time of 3.5 bytes)
Node address	01H
Command	03H
Returned byte number	04H
Higher byte of 0004H	00H
Low byte of 0004H	00H
High byte of 0005H	00H
Low byte of 0005H	00H
Low byte of CRC	43H
High byte of CRC	07H
END	T1-T2-T3-T4 (transmission time of 3.5 bytes)

We reserve the right of this manual contained information
change without prior notice 2014.4