



INVERTER

T9000 Series

Advanced Vector Control Inverter



芜湖众辰自动化设备有限公司
Wuhu ZONCN Automation Equipment Co.,LTD.

1-1 T9000 Technical Specification

Item	ZONCN T9000 Series
Control Mode	VF control ; Sensorless flux vector control (SVC) Close-loop vector control (FVC) (Above 3.7KW)
Maximum frequency	0~600Hz
Carrier frequency	0.5kHz~16kHz The carrier frequency is automatically adjusted based on the load features.
Input frequency resolution	Digital setting:0.01Hz Analog setting: Maximum frequency 0.025%
Start torque	G: Type:0.5Hz/150%(SVC) P: Type:0.5Hz/100%
Speed range	1:100(SVC)
Speed stability accuracy	±0.5%(SVC)
Overload capacity	G Type:60s for 150% of the rated current, 3s for 180% of the rated current. P Type:60s for 120% of the rated current, 3s for 150% of the rated current.
Torque boost	Auto-boost ; Customized boost:0.1%~30.0%
VF curve	Straight-line VF curve; Multi-point VF curve; N-power VF curve(1.2-power,1.4-power,1.6-power,1.8-power,square)
VF separation	2 types: complete separation; half separation
Ramp Mode	Straight-line ramp ; Four groups of acceleration/deceleration time with the range of 0.00'6500.0s
Simple PLC, Multiple preset speeds	It implements up to 16 speeds via the simple PLC function or combination of terminal states
Auto voltage regulation	It can keep constant output voltage automatically when the mains voltage changes
Rapid current limit	It helps to avoid frequent over current faults of the AC drive.
Torque limit and control	It can limit the torque automatically and prevent frequent over current tripping during the running process. Torque control can be implemented in the FVC mode.
Support for multiple PG card	Support for differential input PG card, resolver PG card ,rotating transformer PG card
Rapid current limit	It helps to avoid frequent over current faults of the AC drive.
Timing control	Timing range:0.0Min~6500.0Min
High performance	Control of asynchronous motor are implemented through the high-performance current vector control technology
Rapid dip ride through	The load feedback energy compensates the voltage reduction so that the AC drive can continue to run for a short time
Altitude	Lower than 1000m
Ambient temperature	-10°C~+40°C (de-rated if the ambient temperature is between 40°C-50°C)
Vibration	Less than 5.9m/s ² (0.6g)
Storage temperature	-20°C~+60°C

1-2 T9000 Specification

Model	Rated output power (kW)	Rated input current (A)	Rated output current (A)	Motor Power (kW)
Input voltage (v): 1PH/3PH AC 220V±15%				
T9200-0R4G	0.4	5.4	2.5	0.4
T9200-0R75G	0.75	7.2	5	0.75
T9200-1R5G	1.5	10	7	1.5
T9200-2R2G	2.2	16	11	2.2
T9200-3R7G	3.7	17	16.5	3.7
T9200-5R5G	5.5	26	25	5.5
T9200-7R5G	7.5	35	32	7.5
Input voltage (v): 3PH AC 380V±15%				
T9400-0R4G	0.4	3.4	1.2	0.4
T9400-0R75G	0.75	3.8	2.5	0.75
T9400-1R5G	1.5	5	3.7	1.5
T9400-2R2G	2.2	5.8	5	2.2
T9400-3R7G/5R5P	3.7/5.5	10/15	9/13	3.7/5.5
T9400-5R5G/7R5P	5.5/7.5	15/20	13/17	5.5/7.5
T9400-7R5G/11P	7.5/11	20/26	17/25	7.5/11
T9400-11G/15P	11/15	26/35	25/32	11/15
T9400-15G/18.5P	15/18.5	35/38	32/37	15/18.5
T9400-18.5G/22P	18.5/22	38/46	37/45	18.5/22
T9400-22G/30P	22/30	46/62	45/60	22/30
T9400-30G/37P	30/37	62/76	60/75	30/37
T9400-37G/45P	37/45	76/90	75/90	37/45
T9400-45G/55P	45/55	92/113	90/110	45/55
T9400-55G	55	113	110	55
T9400-75P	75	157	150	75
T9400-75G/90P	75/90	157/180	150/176	75/90
T9400-90G/110P	90/110	180/214	176/210	90/110
T9400-110G/132P	110/132	214/256	210/253	110/132
T9400-132G/160P	132/160	256/307	253/300	132/160
T9400-160G/185P	160/185	307/355	300/340	160/185
T9400-185G/200P	185/200	355/385	340/380	185/200
T9400-200G/220P	200/220	385/430	380/420	200/220
T9400-220G/250P	220/250	430/475	420/470	220/250
T9400-250G/280P	250/280	475/525	470/520	250/280
T9400-280G/315P	280/315	525/610	520/600	280/315
T9400-315G/350P	315/350	610/665	600/640	315/350

★ For more power, please refer to the manual or consult the sales staff

1-3 T9000 hardware configuration list

T9000 Series			
Vector/VF control	Yes	Closed loop vector control	Yes
Built-in brake unit	Support below 37kw. Above 45kw optional	0.1s acceleration and deceleration	Yes
Removable panel	Support below 5.5kw	High speed pulse output	Yes
24v power supply	Yes	DC braking	Yes
STO function	Yes	Profinet / RS485	Yes
I/O extension	Yes	External set filter	Yes
External brake resistor	Yes	Simple PLC function	Yes
Electric reactor	Optional	PID	Yes
EMC filter	Optional	level of protection	IP20
Safety certificate	CE	Simple PLC function	Yes
Collector	1	Multi-protection	Yes

1-4 Product description



MODE: T-9-400-3R7G/5R5P-□

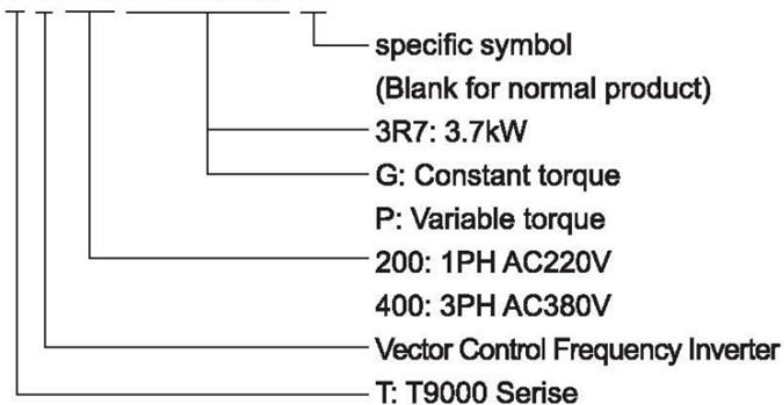

1-5 Typical Wiring diagram

1PH/220V 0.4-3.7KW & 3PH/380V 0.4-5.5KW(★Vector control)

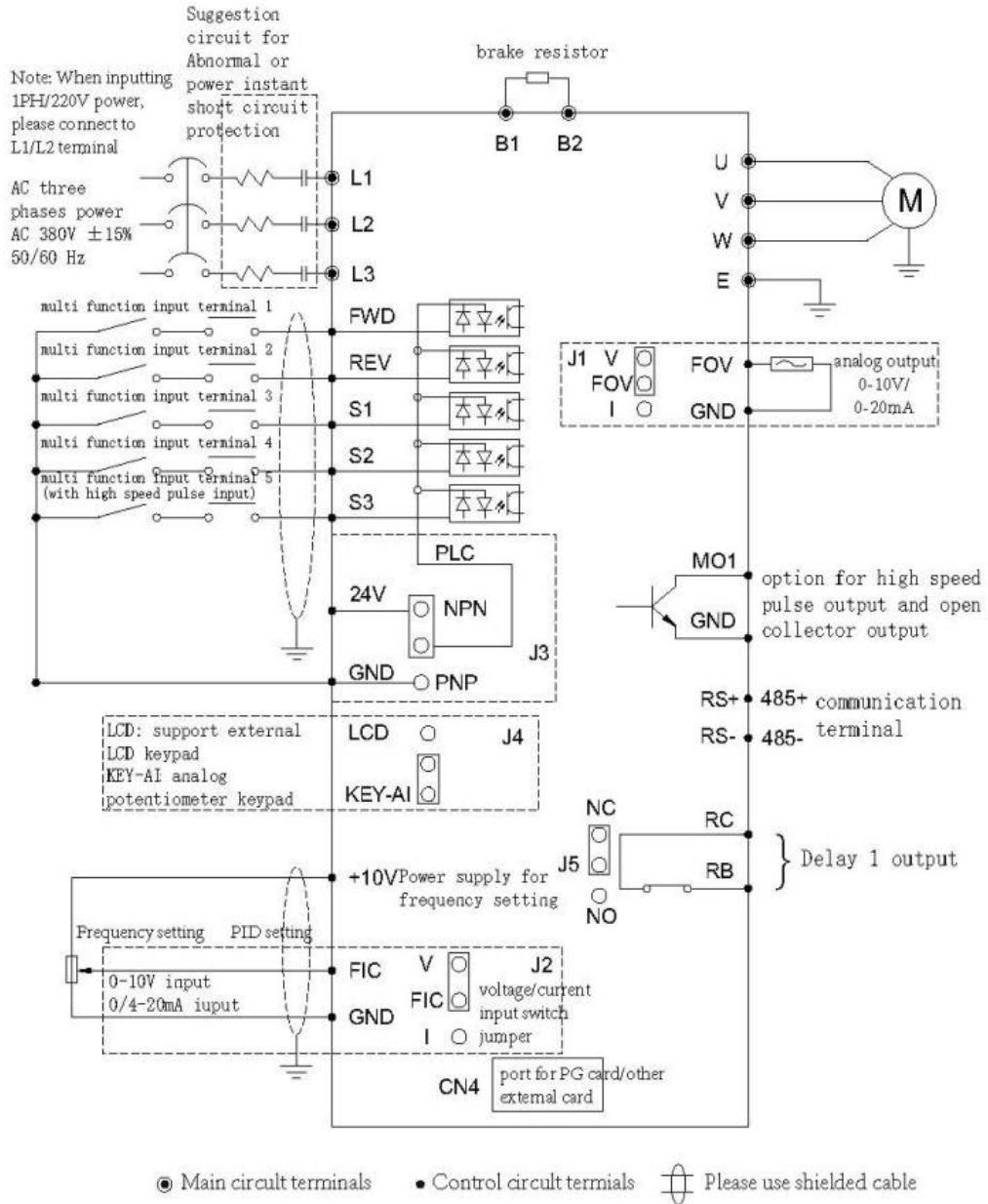

220V/5.5-7.5KW & 380V/7.5KW-160KW

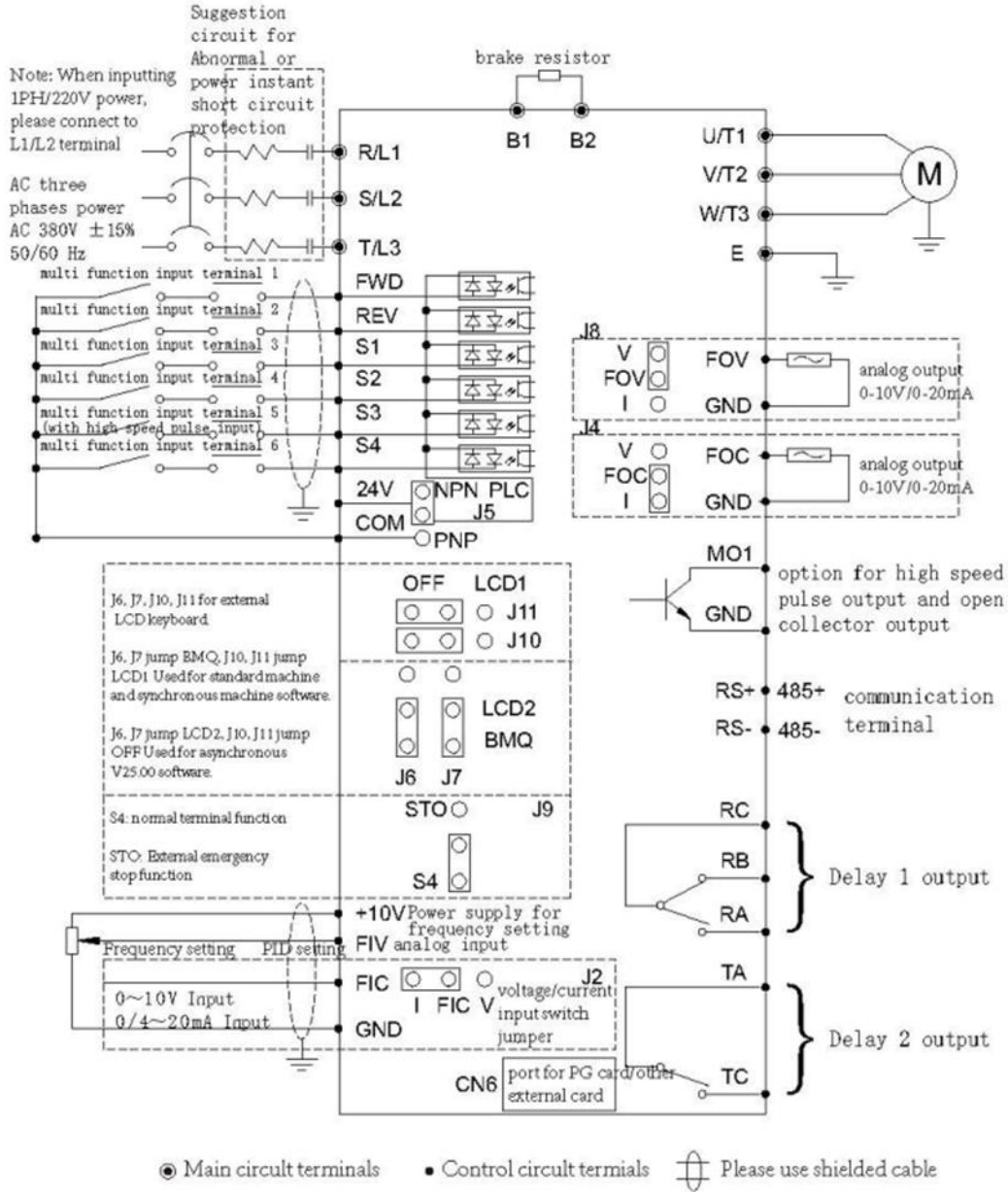

380V/185KW-450KW

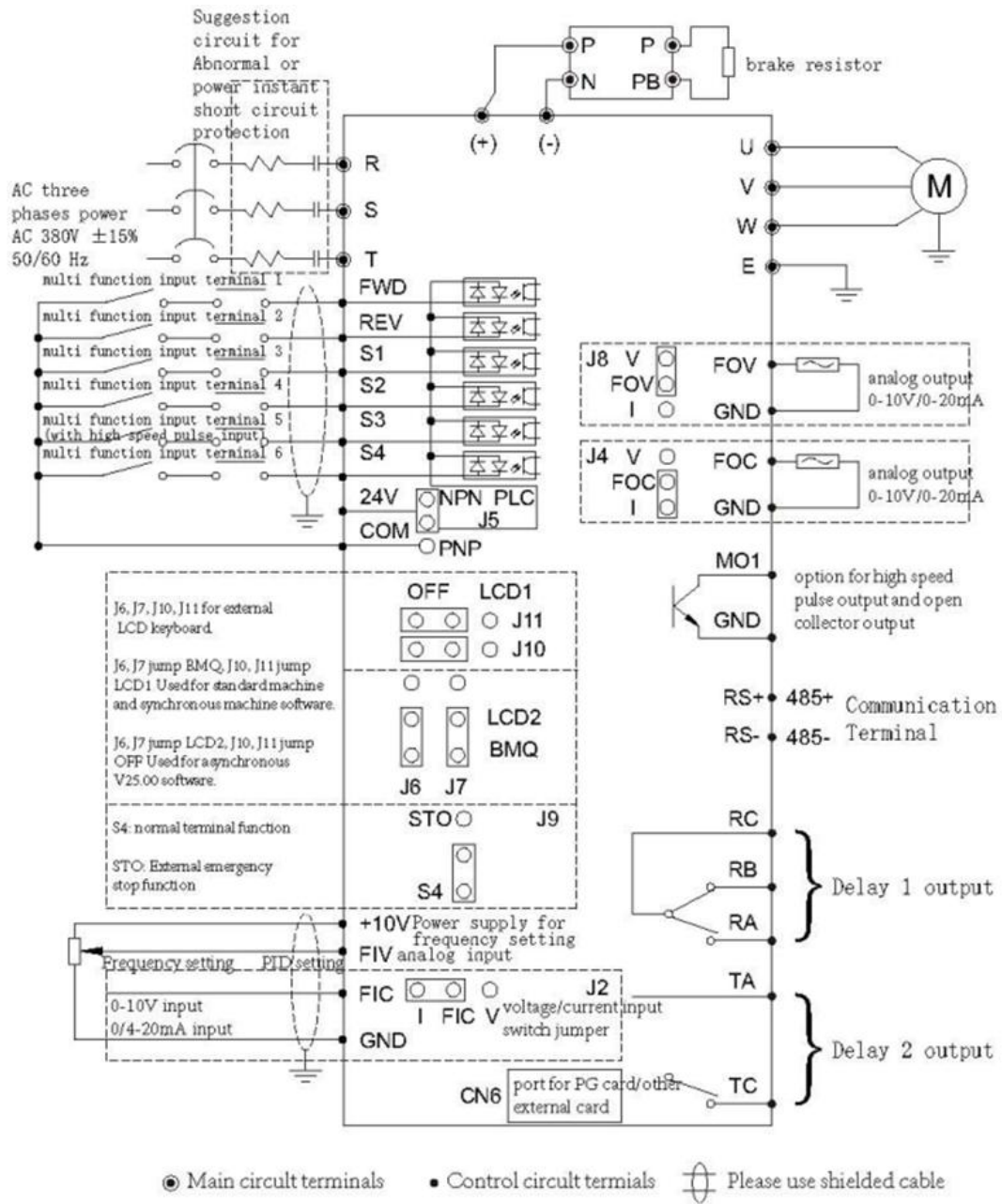

1-6 T9000 series product dimension

SIZE A

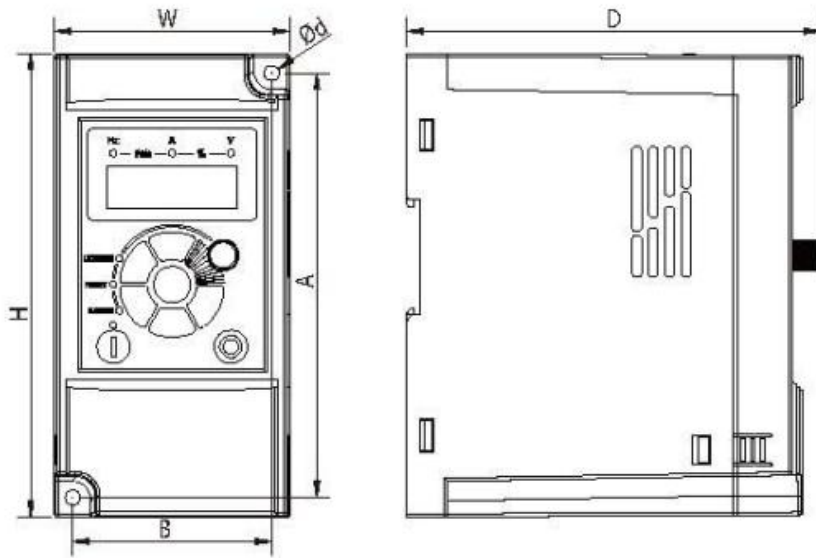

SIZE B

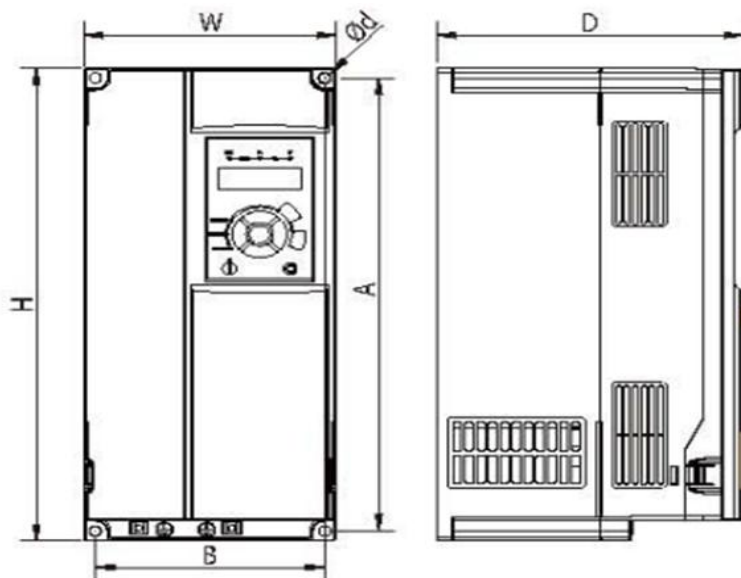

Size	Model	W	H	D	A	B	Φd
A	T9200-0R4G	72	142	127	130	61	4.5
	T9200-0R75G						
	T9200-1R5G						
	T9200-2R2G-VF						
	T9400-0R4G						
	T9400-0R75G						
	T9400-1R5G						
A	T9200-2R2G	85	180	131	167	72	5.5
	T9200-3R7G						
	T9400-3R7G/5R5P						
	T9400-5R5G/7R5P						
B	T9400-7R5G/11P	106	240	168	230	96	4.5
	T9400-11G/15P						
B	T9200-7R5G	151	332	183	318	137	7
	T9400-15G/18.5P						
	T9400-18.5G/22P						
	T9400-22G/30P						
B	T9400-30G/37P	217	400	216	385	202	7
	T9400-37G/45P						

SIZE C

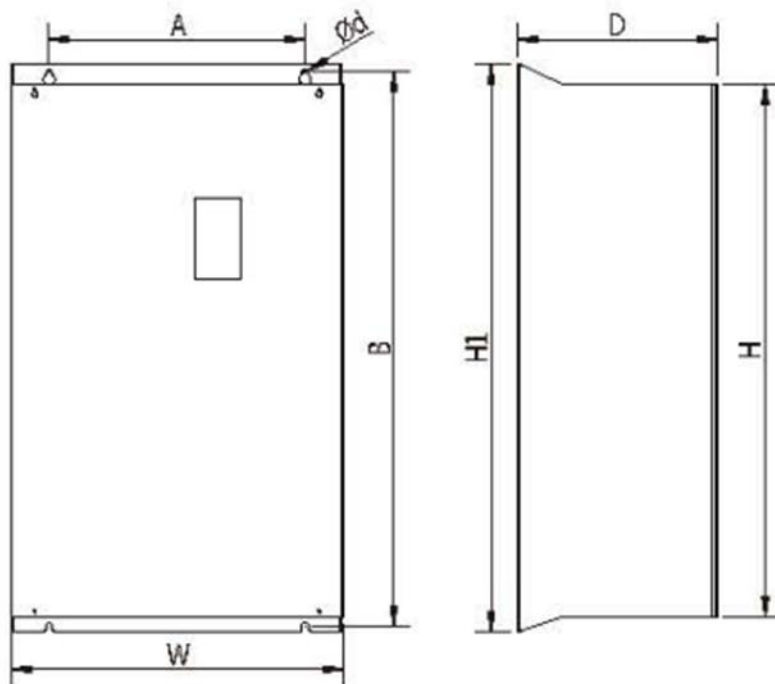

Size	Model	W	H	H1	D	A	B	Φd
C	T9400-45G/55P	300	440	470	240	200	455	9
	T9400-55G							
	T9400-75P							
	T9400-75G/90P	275	590	630	310	200	612	9
	T9400-90G/110P							
	T9400-110G/132P	400	675	715	310	320	695	11
	T9400-132G/160P							
T9400-160G/185P								

SIZE D

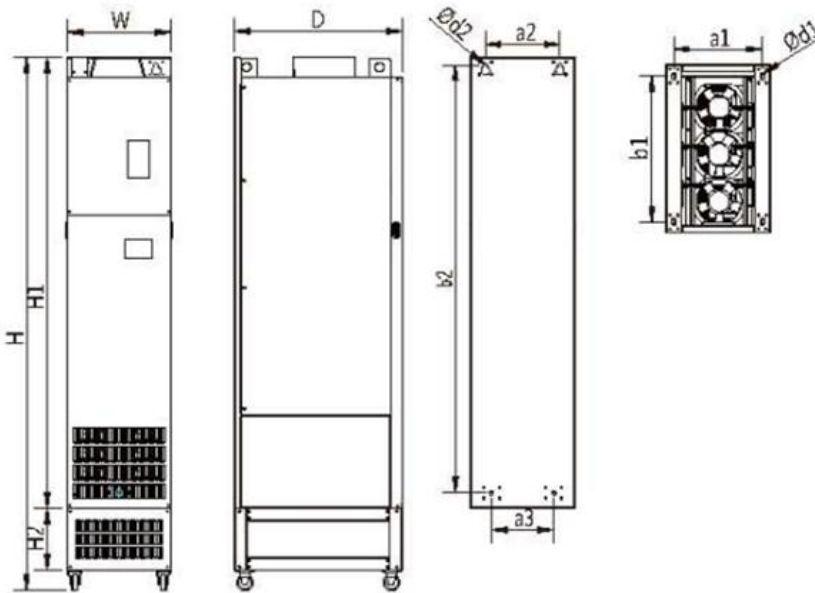

Size	Model	Outline dimension(mm)					Installation size(mm)			Wall-mounted size(mm)			
		W	H	H1	H2	D	A1	B1	D1	A2	A3	B2	D2
D	T9400-185G/200P	300	1445	1180	200	500	250	430	14	220	150	1135	13
	T9400-200G/220P												
	T9400-220G/250P												
	T9400-250G/280P	330	1595	1330	200	545	280	475	14	220	185	1275	13
	T9400-280G/315P	325	1495	1230	200	545	275	470	14	220	185	1175	14
	T9400-315G/350P	335	1720	1455	200	545	285	470	14	220	200	1380	14
	T9400-350G/400P												
	T9400-400G/450P												
T9400-450G/500P													